

Semi-rotary drives DRRD, twin pistons

FESTO



Festo core product range
Covers 80% of your automation tasks

Worldwide:
Superb:
Easy:

Always in stock
Festo quality at an attractive price
Simplified procurement and warehousing

- ★ Generally ready for dispatch from the factory within 24 hours
In stock at 13 Service Centres worldwide
More than 2200 products
- ★ Generally ready for dispatch from the factory within 5 days
Assembled for you at 4 Service Centres worldwide
Up to 6×10^{12} variants per product family

Just look
for the
star!

Characteristics

At a glance

- Rack and pinion principle
- Very high accuracy in the end positions
- Very high load bearing capacity
- Very good axial run-out at the flange shaft
- High mass moments of inertia
- Low backlash and good dynamic response
- Splash-proof design to IP65 based on EN 60529
- Defined interfaces
- Supply port at one end
- Choice of mounting options
- Ideal for use in handling applications

Wide choice of variants

Flange shaft

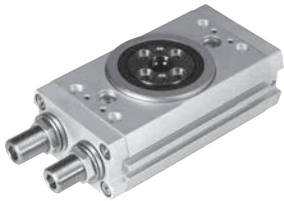

- Size: 8 ... 63
- Torque: 0.2 ... 112 Nm
- Swivel angle: 0 ... 180°

Drive shaft

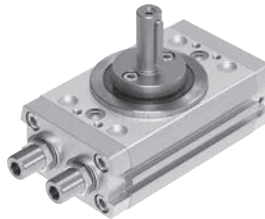

- Size: 12 ... 40
- Torque: 0.8 ... 24.1 Nm
- Swivel angle: 0 ... 180°
- Suitable for ATEX
- Can be ordered as an accessory

Position sensing

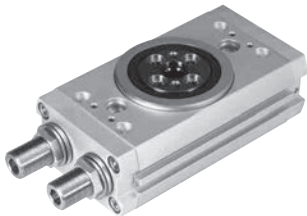

- Size: 8 ... 12
 - C-slot for proximity switch SMT/SME-10
- Size: 16 ... 63
 - T-slot for proximity switch SMT/SME-8

External position sensing (sensor mounting)

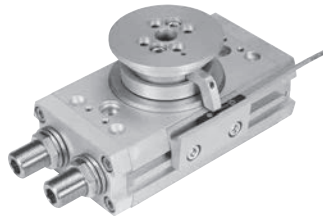

- Size: 16 ... 63
- Position sensing possible directly at the flange shaft
- Inductive proximity switches SIES can be used in combination with external position sensing

Cushioning

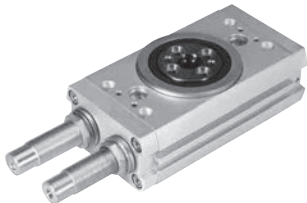

- Size: 12 ... 63
- Five cushioning types available:
 - Elastic cushioning with metal end position (P)
 - Shock absorber (Y9)
 - Shock absorber, hard (Y10)
 - Shock absorber, external (Y12)
 - Shock absorber, soft (Y14)

External cushioning

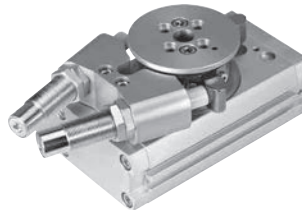

- Size: 12 ... 63
- The full torque can be realised in the end positions in combination with external cushioning

Characteristics

Energy through-feed

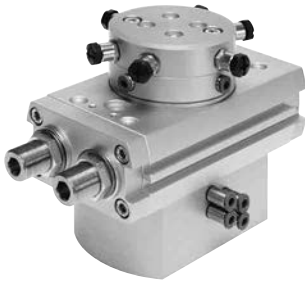

- Size: 16 ... 63
- The energy through-feed can be used to transfer electrical signals or compressed air through the hollow shaft. This enables fast and easy supply of the parts connected to the flange (e.g. gripper)

Also suitable for IO-Link signal data transfer.

Intermediate position



- Size: 16 ... 50
- The semi-rotary drive can additionally be positioned at 90° using the intermediate-position module
- The intermediate position can be approached from both directions
- The cushioning for the intermediate position corresponds to the cushioning for the basic drive. Except in the case of cushioning Y12, when shock absorbers Y9 are used

End-position locking

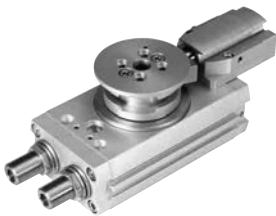

- Size: 16 ... 63
- Mechanical lock in the end positions to prevent unwanted movement in unpressurised condition

Mounting options

Via through-holes

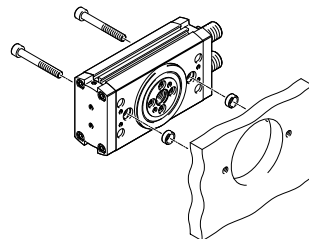
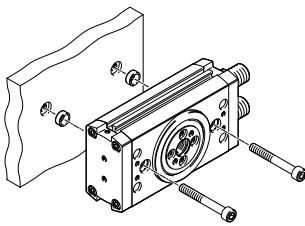

Via thread in the housing profile

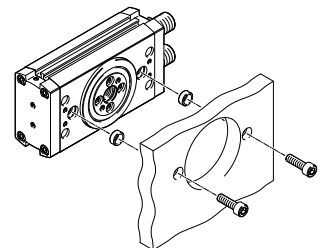
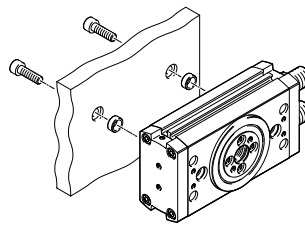

Product range overview

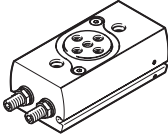
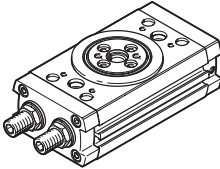
Function	Version	Size	Swivel angle	Energy through-feed						
				[°]	P2	P2E2	P4	P4E6	P8	P8E8
Double-acting	DRRD-8 ... 12									
		8	Max. 200	-	-	-	-	-	-	-
		10	Max. 200	-	-	-	-	-	-	-
		12	Max. 200	-	-	-	-	-	-	-
	DRRD-16 ... 63									
		16	Max. 200	■	■	-	-	-	-	-
		20	Max. 200	■	■	-	-	-	-	-
		25	Max. 200	-	-	■	■	-	-	-
		32	Max. 200	-	-	■	■	-	-	-
		35	Max. 200	-	-	■	■	-	-	-
		40	Max. 200	-	-	-	-	■	■	-
50		Max. 200	-	-	-	-	■	■	-	
63		Max. 200	-	-	-	-	■	■	-	

Product options

Energy through-feed

- P2 Pneumatic, 2 ducts
- P2E2 Pneumatic, 2 ducts; electric, 2 signals
- P4 Pneumatic, 4 ducts
- P4E6 Pneumatic, 4 ducts; electric, 6 signals
- P8 Pneumatic, 8 ducts
- P8E8 Pneumatic, 8 ducts; electric, 8 signals

Product range overview

Function	Size	Cushioning					Position sensing	EU certification	Intermediate position	End-position locking	External sensor mounting	Splash-proof design	→ Page/ Internet
		P	Y9	Y10	Y12	Y14							
Double-acting	DRRD-8 ... 12												
	8	■	-	-	-	-	■	-	-	-	-	-	6
	10	■	-	-	-	-	■	-	-	-	-		
	12	■	■	-	■	-	■	-	-	-	-		
	DRRD-16 ... 63												
	16	■	■	-	■	■	■	■	■	■	■	■	20
	20	■	■	-	■	■	■	■	■	■	■	■	
	25	■	■	■	■	■	■	■	■	■	■	■	
	32	■	■	-	■	■	■	■	■	■	■	■	
	35	■	■	■	■	■	■	■	■	■	■	■	
	40	■	■	■	■	■	■	■	■	■	■	■	
	50	-	■	■	■	-	■	■	■	■	■	■	
	63	-	■	■	■	-	■	■	-	■	■	■	

Product options

Cushioning

- P Elastic cushioning at both ends
Y9 Linear shock absorber, self-adjusting at both ends, internal
Y10 Linear shock absorber, self-adjusting at both ends, hard, internal
Y12 Linear shock absorber, self-adjusting at both ends, external
Y14 Linear shock absorber, self-adjusting at both ends, soft, internal

System example

System product for handling and assembly technology

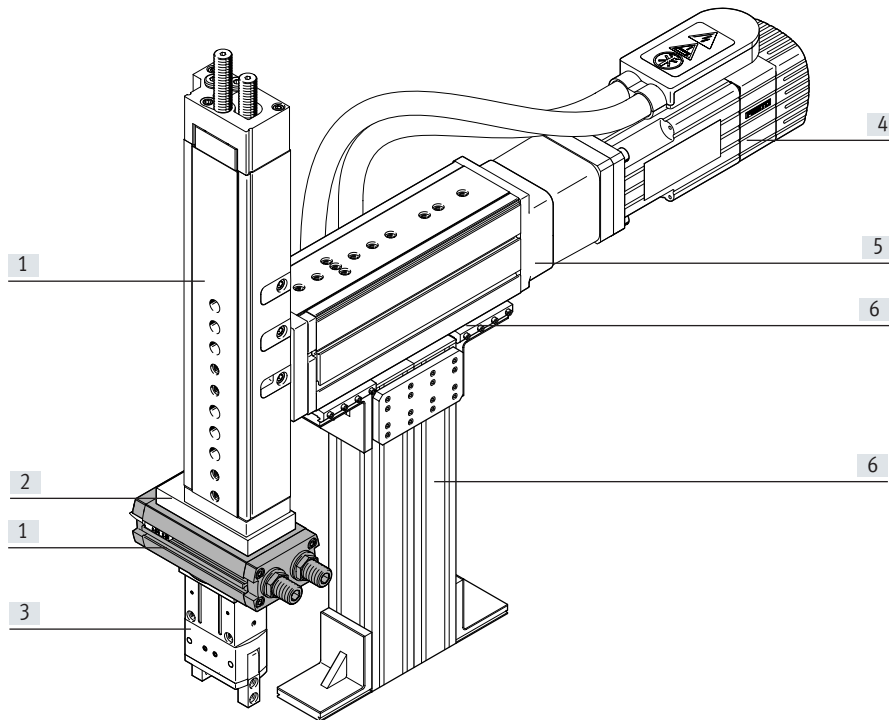

System components and accessories

	Description	→ Page/Internet
[1] Drives	Wide range of combinations possible within handling and assembly technology	drive
[2] Adapters	For drive/drive and drive/gripper connections	adapter-kit
[3] Gripper	Wide range of variation options within handling and assembly technology	gripper
[4] Motors	Servo and stepper motors, with or without gear unit	motor
[5] Axes	Wide range of combinations possible within handling and assembly technology	axis
[6] Basic components	Profiles and profile connections as well as profile/drive connections	basic component
- Installation components	For a clear, safe layout of electrical cables and tubing	Installation component

Type codes

001	Series	
DRRD	Semi-rotary drive, double piston	

002	Size	
8	8	
10	10	
12	12	
16	16	
20	20	
25	25	
32	32	
35	35	
40	40	
50	50	
63	63	

003	Nominal swivel angle [°]	
180	180	

004	Output shaft	
FH	Flanged shaft, hollow	

005	Energy through-feed	
	None	
P2	Pneumatic, 2 ducts	
P2E2	Pneumatic, 2 ducts and electric, 2 signals	
P4	Pneumatic, 4 ducts	
P4E6	Pneumatic, 4 ducts and electric, 6 signals	
P8	Pneumatic, 8 ducts	
P8E8	Pneumatic, 8 ducts and electrical, 8 signals	

006	Cushioning	
P	Elastic cushioning rings/plates on both sides	
Y9	Shock absorber, self-adjusting, linear, at both ends	
Y10	Shock absorber, self-adjusting, linear at both ends, hard	
Y12	Shock absorber, self-adjusting, linear at both ends, external	
Y14	Shock absorber, self-adjusting, linear on both sides, soft	

007	Position sensing	
A	For proximity sensor	

008	EU certification	
	None	
EX4	II 2GD	

009	Intermediate position	
	None	
PS1	1 intermediate position	

010	End-position locking	
	None	
E1	Both sides	

011	Sensor mounting, external	
	None	
R	Mounting rail for sensors	

012	Version	
	Standard	
SG	Protected against splash water	

013	Operating instructions	
	With operating instructions	
DN	Without operating instructions	

Peripherals overview

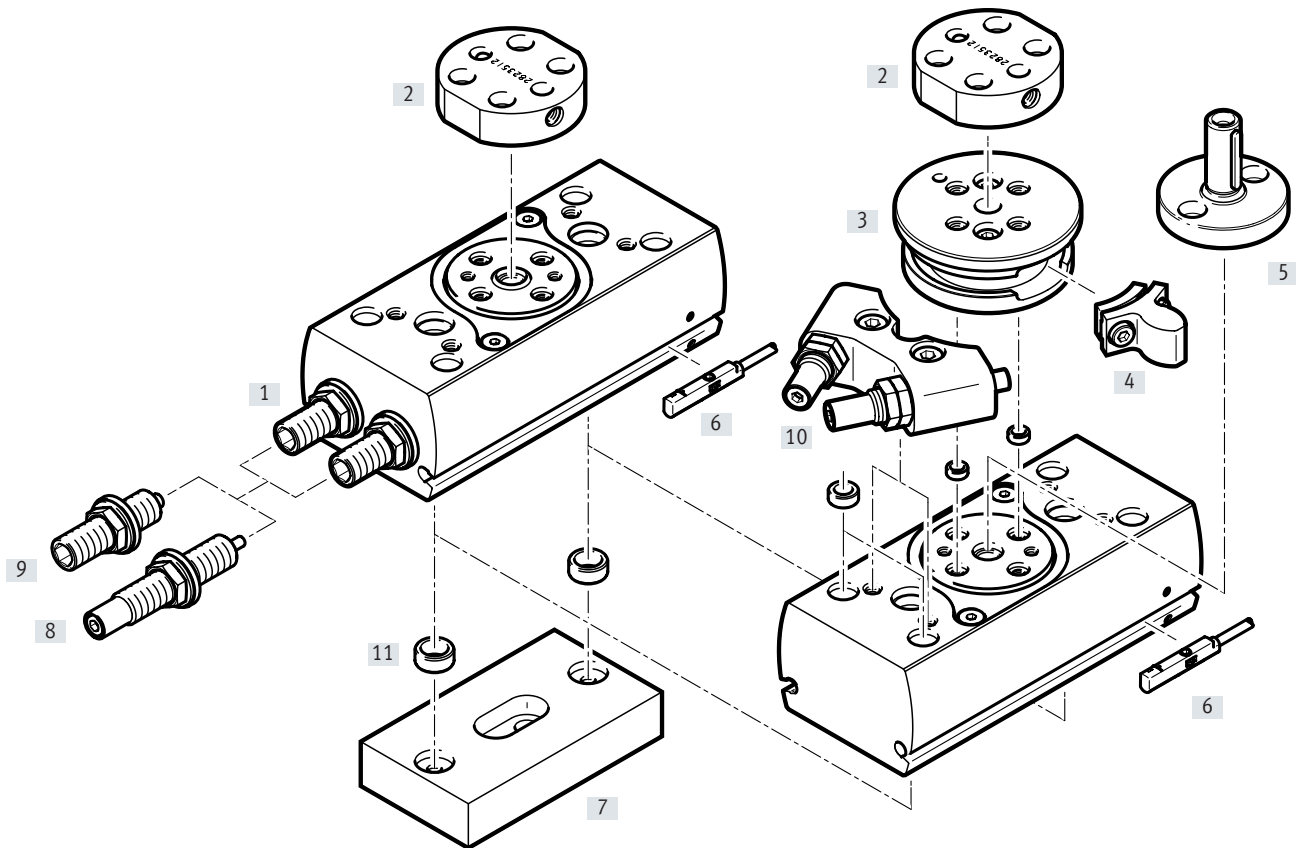

Peripherals overview

Variants, mounting components and accessories		Description	Size			→ Page/ Internet
			8	10	12	
[1]	Semi-rotary drive DRRD	Double-acting	■	■	■	6
[2]	Adapter kit DHAA	<ul style="list-style-type: none"> Connecting plate between semi-rotary drive and gripper Included in the scope of delivery: 2 centring sleeves and screws 	■	■	■	gripper
[3]	Flange module	<ul style="list-style-type: none"> Required for mounting the component [4] 	–	–	■	18
[4]	Stop element	<ul style="list-style-type: none"> Serves as an end stop in combination with external shock absorbers (Y12) Two stop elements are included in the scope of delivery of external shock absorbers (Y12) 	–	–	■	18
[5]	Drive shaft DARF-Q11	<ul style="list-style-type: none"> The interface corresponds with that of semi-rotary drive DRQD The drive shaft should only be mounted directly onto the flange shaft Suitable for ATEX 	–	–	■	56
[6]	Proximity switch SMT/SME-10	For sensing the piston position	■	■	■	60
[7]	Adapter kit DHAA	Connecting plate between semi-rotary drive and drive	■	■	■	65
[8]	Shock absorber Y9	Linear shock absorber, self-adjusting at both ends	–	–	■	19
[9]	Shock absorber P	Elastic cushioning elements with metal end position, at both ends	■	■	■	19
[10]	Shock absorber, external Y12	<ul style="list-style-type: none"> Linear shock absorber, self-adjusting at both ends, external Included in the scope of delivery: [3], 2x [4], [10] 	–	–	■	19
[11]	Centring sleeve ZBH	For centring attachments (two centring sleeves for mounting the semi-rotary drive included in the scope of delivery)	■	■	■	59

Data sheet

Function

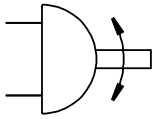

www.festo.com

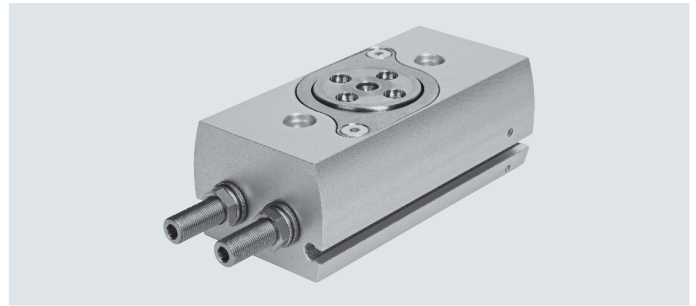

- Diameter
8 ... 12 mm
- Torque
0.2 ... 0.8 Nm

General technical data		8	10	12
Size		8	10	12
Design		Gear rack/pinion		
Mode of operation		Double-acting		
Pneumatic connection		M3	M3	M5
Type of mounting		With through-hole		
		Via female thread		
Swivel angle	[°]	180 (→ page 10)		
Cushioning with fixed stop				
DRRD-...-P		Elastic cushioning at both ends		
DRRD-...-Y9		-		Linear shock absorber, self-adjusting at both ends
DRRD-...-Y12		-		External linear shock absorber, self-adjusting at both ends
Repetition accuracy	[°]	≤ 0.03		
Axial run-out ¹⁾	[mm]	≤ 0.02		
Max. axial load (static)				
Pulling	[N]	260	260	330
Pushing	[N]	700	1100	1400
Mounting position		Any		

1) Axial run-out in new condition

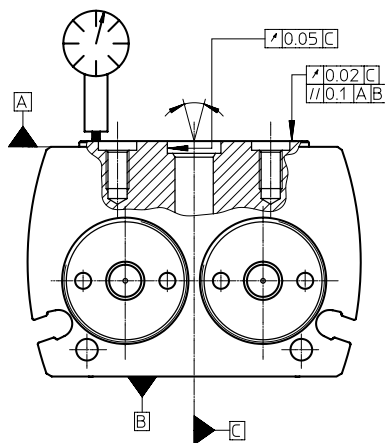

Data sheet

Operating and environmental conditions		
Operating medium		Compressed air to ISO 8573-1:2010 [7:4:4]
Note on operating/pilot medium		Lubricated operation possible (in which case lubricated operation will always be required)
Operating pressure		
DRRD-...-P	[bar]	3 ... 8
DRRD-...-Y9/-Y12	[bar]	2 ... 10
Ambient temperature	[°C]	-10 ... +60
Storage temperature	[°C]	-20 ... +60

Weights [g]			
Size	8	10	12
DRRD-...-P	155	245	380
DRRD-...-Y9	-	-	385
DRRD-...-Y12	-	-	500

Forces and torques				
Size	8	10	12	
Theoretical torque at 6 bar	[Nm]	0.2	0.4	0.8
Max. permissible mass moment of inertia				
DRRD-...-P	[kgcm ²]	15	20	80
DRRD-...-Y9	[kgcm ²]	-	-	300
DRRD-...-Y12	[kgcm ²]	-	-	300

 **Note**

If, in the end positions, a torque which exceeds 50% of the theoretical torque acts against the direction of rotation, no exact end position is guaranteed.

This can be avoided by using external shock absorbers (Y12) or a semi-rotary drive with double the torque.

Materials

Sectional view

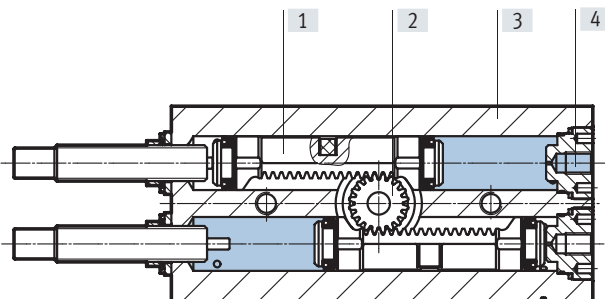

Semi-rotary drive	
[1] Piston	Copper base alloy
[2] Flange shaft	High-alloy stainless steel
[3] Housing	Smooth-anodised wrought aluminium alloy
[4] Port plug	High-alloy stainless steel
Seals	NBR
Piston seal	TPE-U(PU)
Note on materials	RoHS-compliant
	Contains paint-wetting impairment substances

Data sheet

Swivel angle

Fundamentally, the following applies:

Swivel angle $\alpha \geq$ cushioning angle β

Swivel angle $\alpha = 180^\circ + \Delta\alpha_{\text{right}} + \Delta\alpha_{\text{left}}$

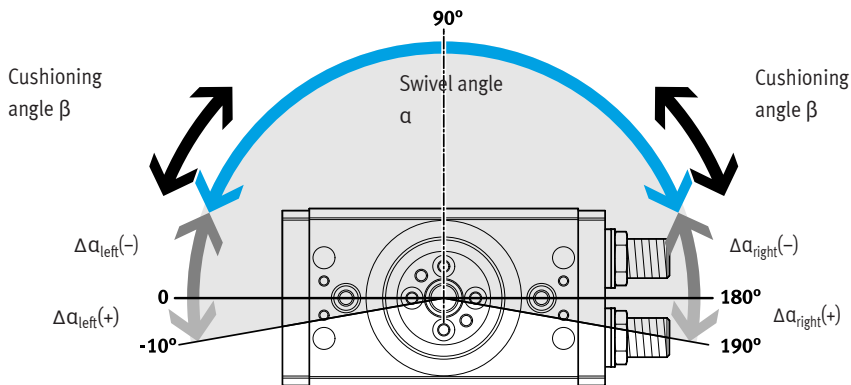

Size		8	10	12
Swivel angle α	[°]	180		
Min. swivel angle $\alpha^{1)}$				
DRRD-...-P	[°]	38	37	32
DRRD-...-Y9	[°]	-	-	48
DRRD-...-Y12	[°]	-	-	20
Max. swivel angle α				
DRRD-...	[°]	200		
DRRD-...-Y12	[°]	-	-	192
Swivel angle adjustment α per side (infinitely adjustable)				
DRRD-...-P	[°]	-100 ... +10		
DRRD-...-Y9	[°]	≥ -100 ... +10		
DRRD-...-Y12	[°]	-	-	-92 ... +6
Cushioning angle α				
DRRD-...-P	[°]	38	37	32
DRRD-...-Y9	[°]	-	-	48
DRRD-...-Y12	[°]	-	-	10

1) It is possible to set smaller swivel angles. However, this reduces the cushioning energy.

Swivel angle adjustment

Clockwise direction of rotation:

- Swivel angle decreases

Anticlockwise direction of rotation:

- Swivel angle increases

The swivel angle is adjusted via the cushioning elements using an Allen key. Any reduction in the swivel angle should preferably be evenly split between the two end positions.

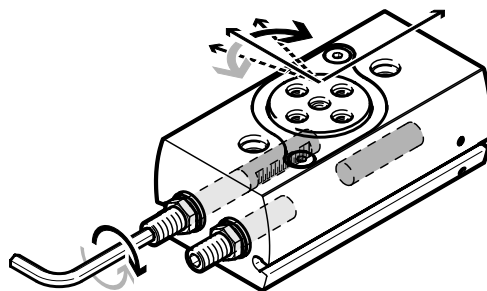

Data sheet

**Max. permissible mass moment of inertia J at the flange shaft as a function of swivel time t
 (at room temperature and an operating pressure of 6 bar)**

Size 8 with cushioning P

Swivel angle 90°/180°

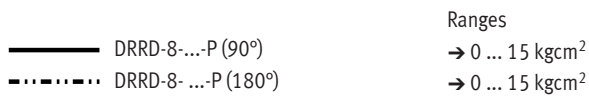
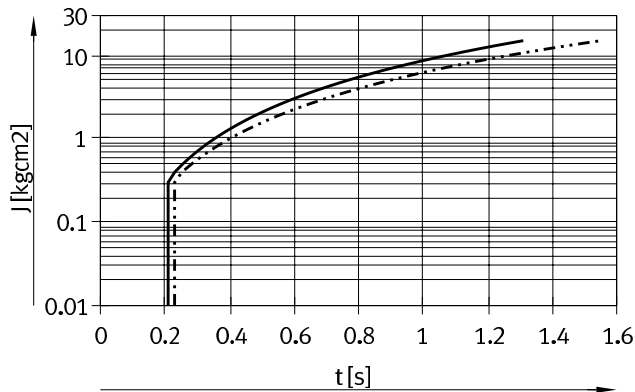

Size 10 with cushioning P

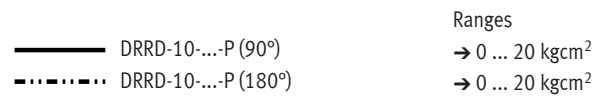
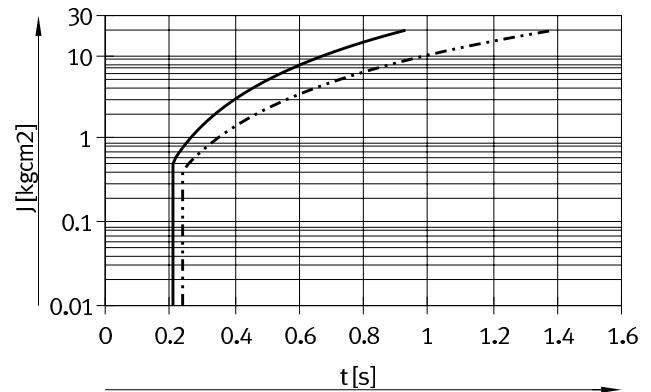

Size 12 with cushioning P/Y9

Swivel angle 90°

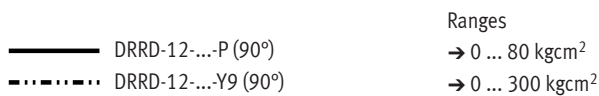
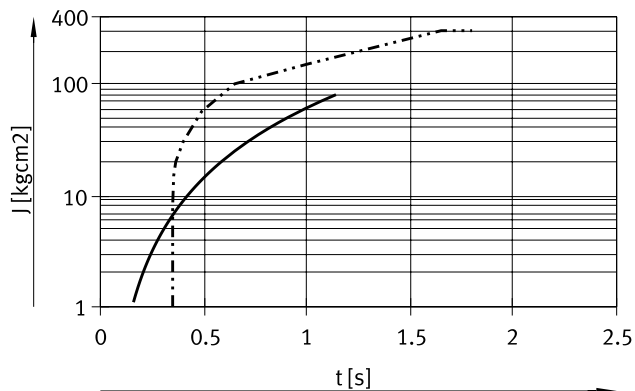

Swivel angle 180°

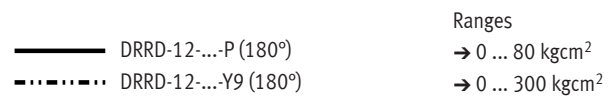
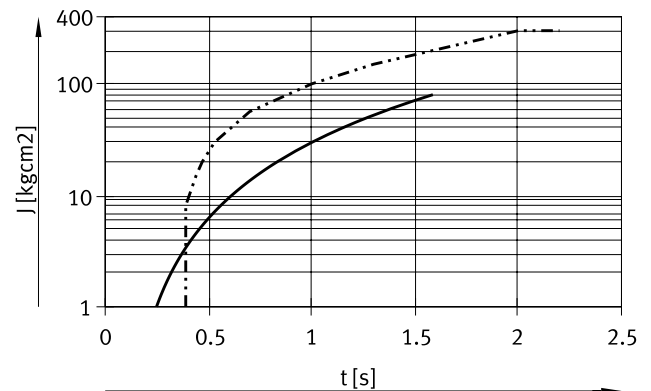

Size 12 with cushioning Y12

Swivel angle 90°/180°

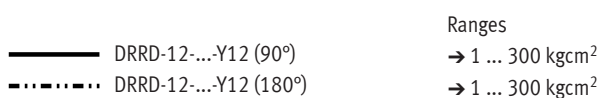
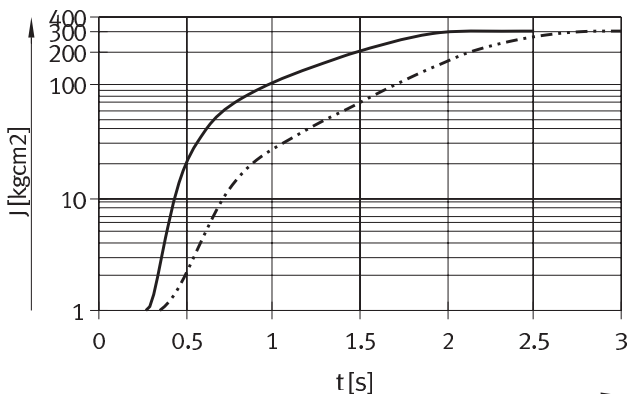

Data sheet

Max. load capacity at the flange shaft

The zero point for dimension z is always the flange level of the basic drive, independently of the attachments (flange module).

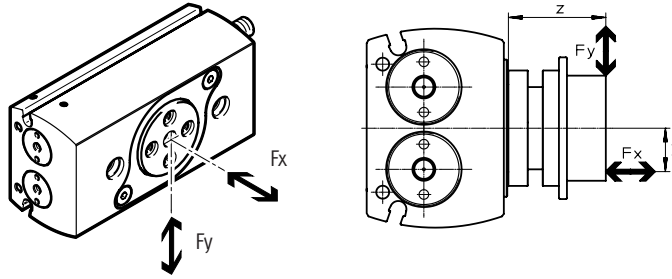

The following equation applies to combined loads (axial and radial):

$$\frac{F_y(z)}{F_{y\max.}(z)} + \frac{F_x(y)}{F_{x\max.}(y)} \leq 1$$

Dynamic values

Max. radial force F_y as a function of distance z

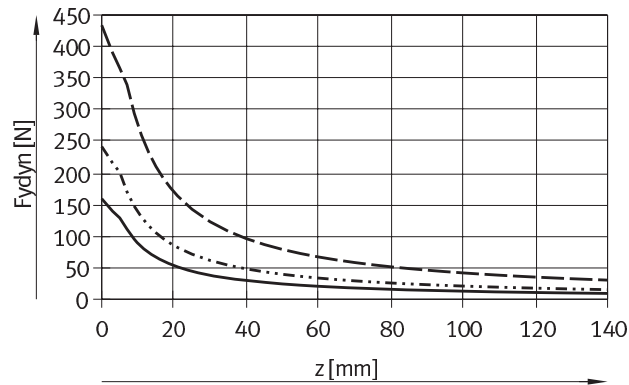

— DRRD-8
 - - - DRRD-10
 - · - · DRRD-12

Max. axial force F_x as a function of distance y

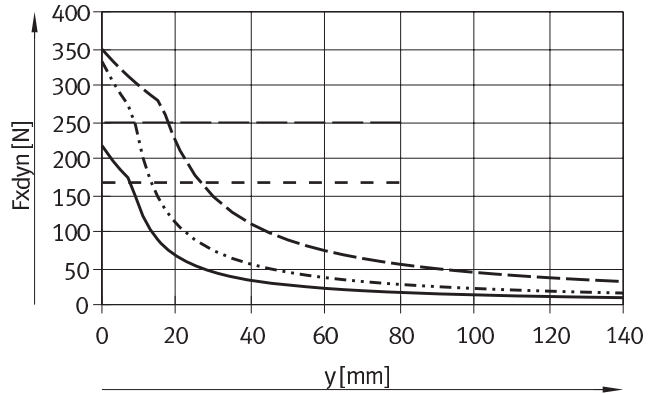

······ Tensile force limit DRRD-8/10
 - · - · Tensile force limit DRRD-12

Static values

Max. radial force F_y as a function of distance z

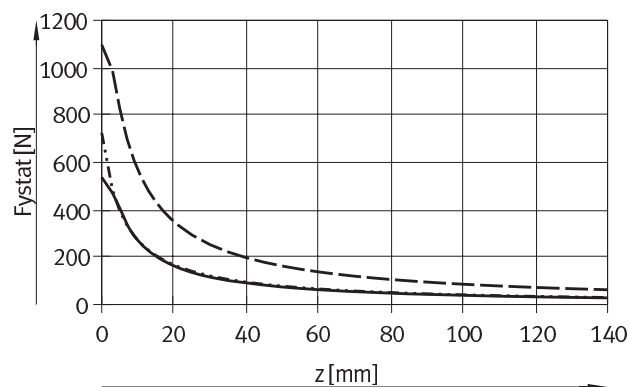

— DRRD-8
 - - - DRRD-10
 - · - · DRRD-12

Max. axial force F_x as a function of distance y

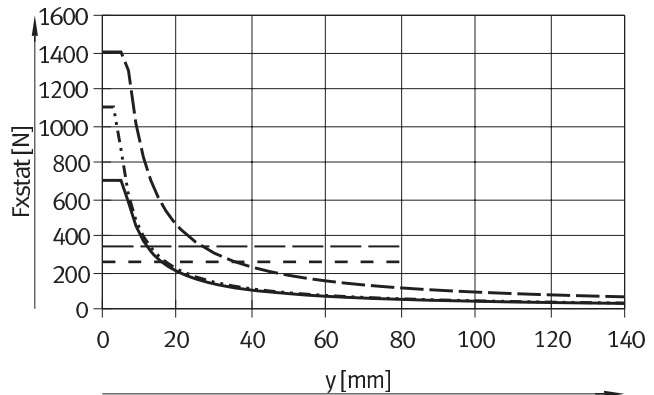

······ Tensile force limit DRRD-8/10
 - · - · Tensile force limit DRRD-12

Data sheet

Max. load capacity on the drive shaft (DARF-Q11)Max. radial forces F_y / axial forces F_x / bending moment M

- For the radial forces F_y , the limits of the flange shaft → page 14 and max. bending moment of the drive shaft apply → table below.
- The bending moment represents the load limit of the drive shaft and must not be exceeded.
- The zero point for dimension z is always the flange level of the basic drive, independently of the attachments (flange module).
- The axial force represents an additional load.

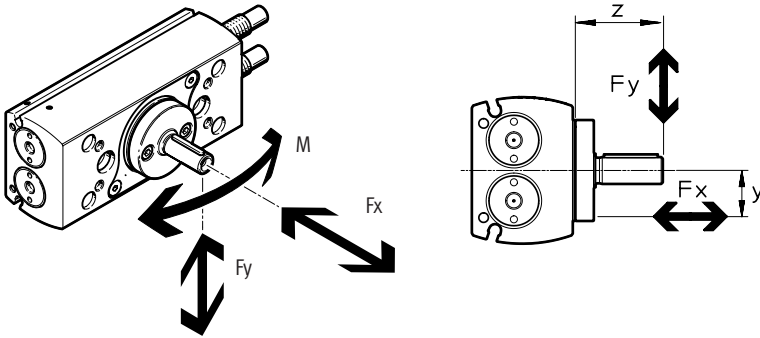

Size		12
Axial force F_x	[N]	170
Bending moment M	[Nm]	5.44

Data sheet

Dimensions

Download CAD data → www.festo.com

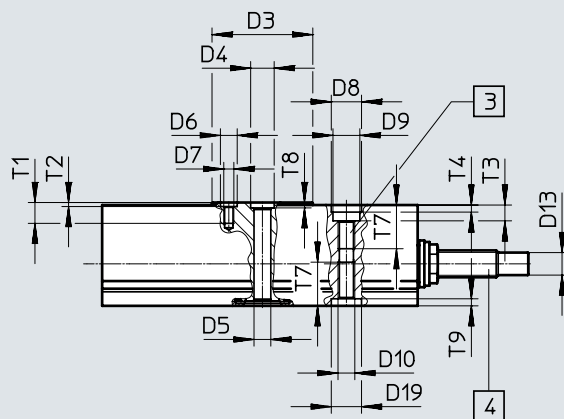
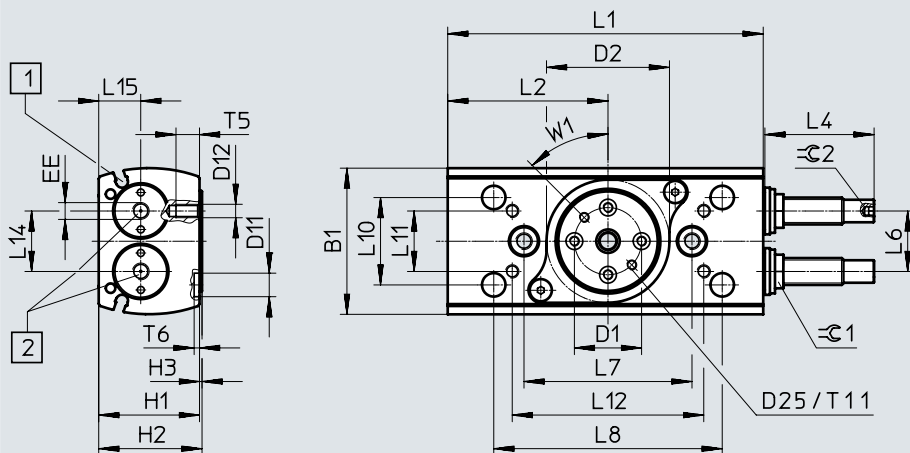

DRRD-...-P

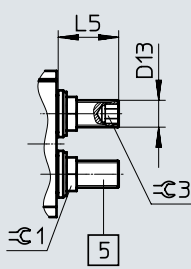

DRRD-8/10

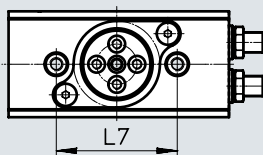

Note

Illustrated position of the flange shaft corresponds to the mid-position (swivel angle 90°).
Dimensions D25, T11 and W1 only for size 12

- [1] Sensor slots for proximity switch
- [2] Supply ports
- [3] Mounting thread
- [4] Shock absorber (DRRD-...-Y9)
- [5] Cushioning elements (DRRD-...-P)

Data sheet

Size	B1 ±0.25	D1 ∅ ±0.025	D2 ∅ +0.1	D3 ∅	D4 ∅ H7	D5 ∅ ±0.1	D6 ∅ H7	D7	D8 ∅ H7	D9 ∅	D10
8	31.5	12	26	20.4	5	3	5	M3	7	6	M4
10	38	15	32	24	5	3	5	M3	7	6	M4
12	43.5	20	37	30	7	5	5	M3	9	8	M5

Size	D11 ∅ H7	D12	D13	D19 ∅ H7	D25	H1 +0.4	H2 ±0.2	H3 +0.2/-0.6	L1 ±0.1	L2 +0.1	L6
8	-	-	M6x0.5	7	-	24.5	25.25	0.75	65.6	32.2	13 _{-0.1}
10	-	-	M6x0.5	7	-	27.5	28.25	0.75	74	38.3	15.2 _{-0.1}
12	7	M4	M8x1	9	M3	30	30.75	0.75	93.9	47.7	18 ^{+0.1}

Size	L7 ±0.02	L8 ±0.2	L10 ±0.02	L11 ±0.15	L12 ±0.2	L14	L15 -0.1	T1	T2 +0.1	T3	T4 +0.4/-0.1
8	36	-	-	-	-	13	11.1	4.8	1.2	3.4	1.5
10	44	-	-	-	-	15.2	11.1	6.2	1.2	3.4	1.5
12	50	68	26	18	57	18	12.5	5.4	1.2	4.7	2.1

Size	T5	T6 +0.4/-0.1	T7	T8 +0.1	T9 +0.1	T11	EE	W1	∠1	∠2	∠3
8	-	-	10.5	1.2	1.6	-	M3	-	10	-	3
10	-	-	10	1.2	1.6	-	M3	-	10	-	3
12	7	1.6	13	1.6	2.1	5.5	M5	45°	10	2.5	5

Size	Dimension with 180° swivel angle		Swivel angle adjustment range		
	L4	L5	L4 min./max.	L5 min./max.	1 mm = ...°
8	-	11.1	-	-6.1/+0.8	16.4
10	-	12.6	-	-7.6/+1.2	13.64
12	28	17	-1.9/+1.9	-11/+1.8	9.6

Data sheet

Dimensions – Variants

Download CAD data → www.festo.com

Y12 – With external shock absorber

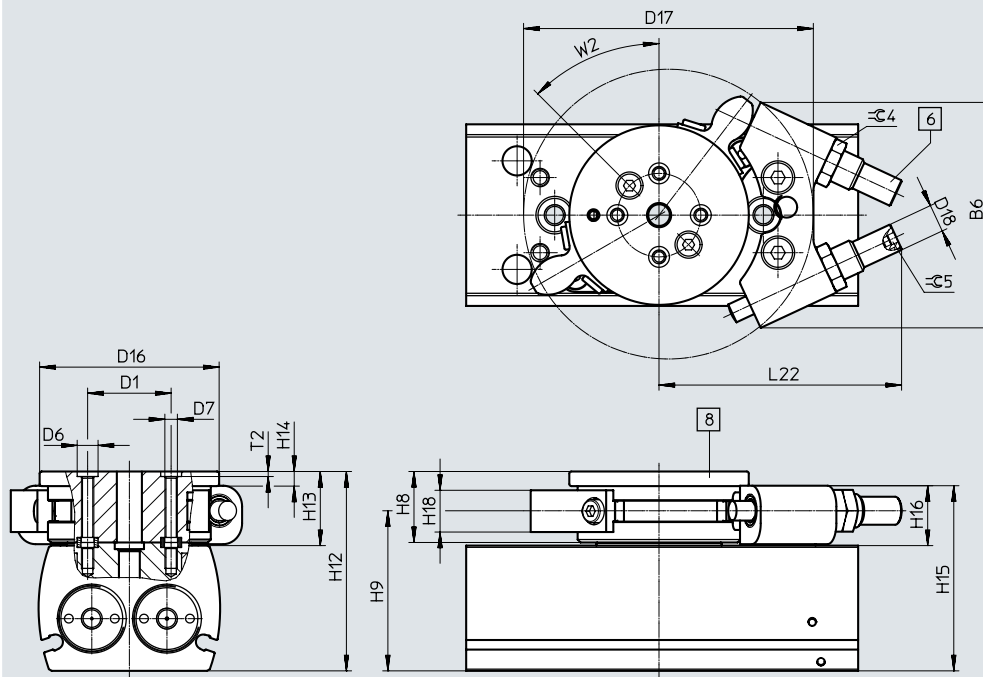

[6] Shock absorber
[8] Flange module

Size	B6	D1	D6	D7	D16	D17	D18	H8	H9	H12
	±0.2	∅ ±0.025	∅ H7	M3	∅ 43	69.4	M8x1	±0.1	38.25	±0.3
12	54	20	5	M3	43	69.4	M8x1	17	38.25	47.75
Size	H13	H14	H15	H16	H18	L22	T2	W2	∠ 4	∠ 5
						max.	+0.1	45°	10	2.5
12	17.75	3.5	44	14	10	58.2	1.2	45°	10	2.5

Ordering data

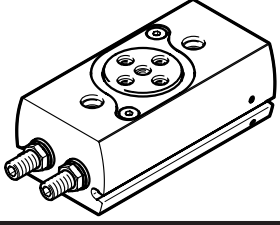
Ordering data DRRD	Size	Swivel angle [°]	Part no.	Type
	P – Elastic cushioning rings/plates at both ends			
	8	180	2223060	DRRD-8-180-FH-PA
	10		2350968	DRRD-10-180-FH-PA
	12		2282067	DRRD-12-180-FH-PA
	Y9 – Linear shock absorber, self-adjusting at both ends			
	12	180	2399248	DRRD-12-180-FH-Y9A

Ordering table – modular product system		Conditions	Code	Enter code
Size	12			
Module no.	574398			
Function	Semi-rotary drive		DRRD	DRRD
Size	12		-12	-12
Nominal swivel angle	180°		-180	-180
Output shaft	Flange shaft, hollow		-FH	-FH
Cushioning	Elastic cushioning rings/plates at both ends		-P	
	Linear shock absorber, self-adjusting at both ends		-Y9	
	Linear shock absorber, self-adjusting at both ends, external		-Y12	
Position sensing	Via proximity switch		A	A
Operating instructions	With operating instructions			
	Without operating instructions		-DN	

Peripherals overview

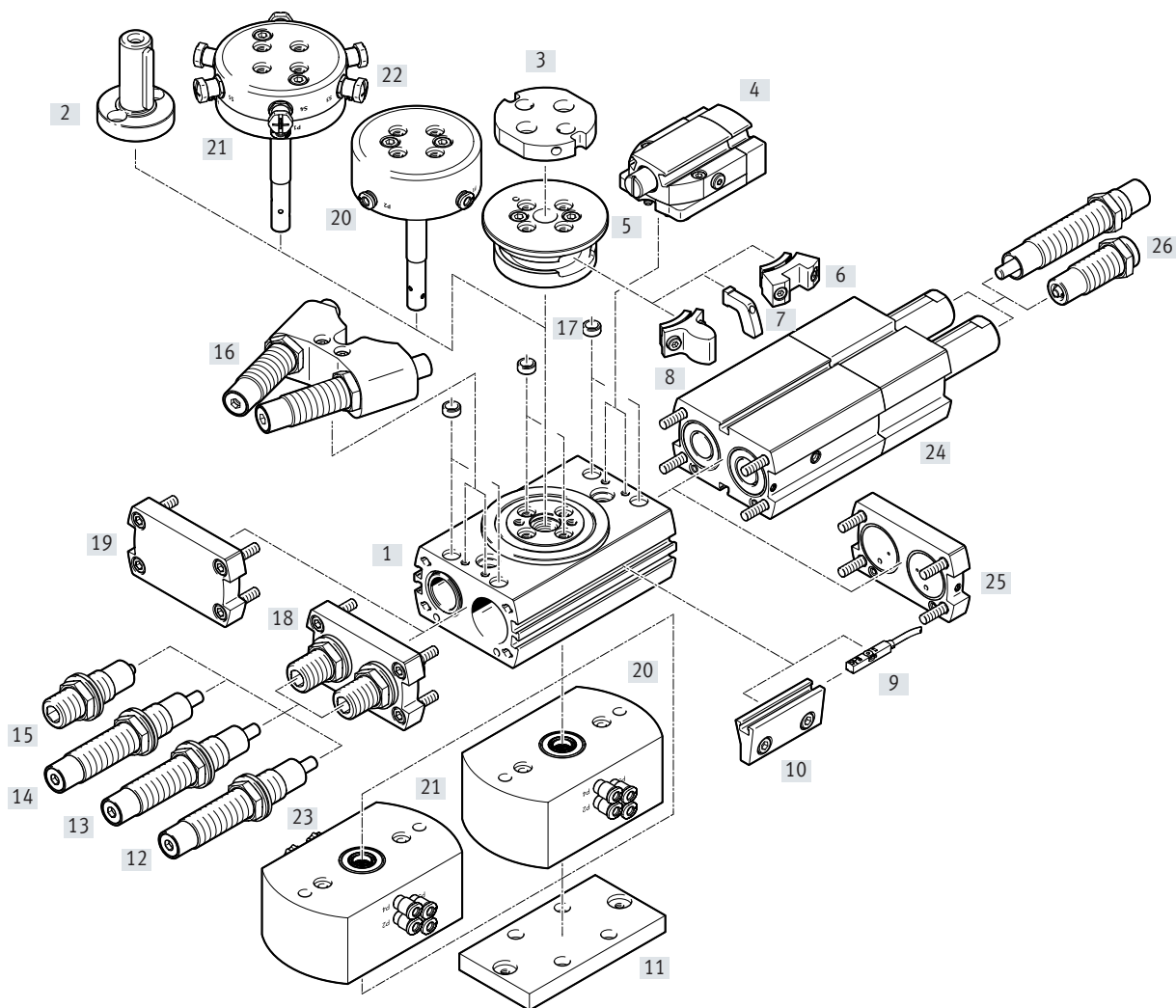

Variants, mounting components and accessories

	Description	Size								→ Page/ Internet
		16	20	25	32	35	40	50	63	
[1]	Semi-rotary drive DRRD	Double-acting								20
[2]	Drive shaft ¹⁾ DARF-Q11	<ul style="list-style-type: none"> The interface corresponds with that of semi-rotary drive DRQD The drive shaft should only be mounted directly onto the flange shaft Suitable for ATEX 								56
[3]	Adapter kit DHAA	<ul style="list-style-type: none"> Connecting plate between semi-rotary drive and gripper Included in the scope of delivery: 2 centring sleeves and screws 								gripper
[4]	End-position locking E1 ¹⁾ (clamping unit DADL-...-EL as an accessory)	<ul style="list-style-type: none"> Mechanical lock in the end positions to prevent unwanted movement when unpressurised Included in the scope of delivery: [4], [5], 2x [6] 								57
[5]	Flange module	Required to mount components [6], [7] and [8]								57
[6]	Clamping component (Type: DADL-EC)	Secures the semi-rotary drive DRRD when the cylinder [4] is advanced								59
[7]	Switch lug DASI-Q11-...-SL	For sensing the piston position using e.g. inductive proximity switches SIES-8M → page 61, in combination with sensor bracket [10]								59

Peripherals overview

Variants, mounting components and accessories		Description	Size							→ Page/ Internet	
			16	20	25	32	35	40	50		63
[8]	Stop element	Serves as an end stop in combination with external shock absorbers (Y12)	■	■	■	■	■	■	■	■	55
[9]	Proximity switch SMT/SME-8	For sensing the piston position	■	■	■	■	■	■	■	■	60
	Position transmitter SMAT-8M	Analogue position feedback from 0 ... 10 V possible	■	■	■	■	■	■	■	■	62
[10]	Sensor mounting R (sensing kit DASI-...-KT as an accessory)	<ul style="list-style-type: none"> For sensing the piston position using e.g. inductive proximity switches SIES-8M → page 61 Included in the scope of delivery: [5], 2x [7], 2x [10] 	■	■	■	■	■	■	■	■	58
[11]	Adapter kit DHAA	Connecting plate between semi-rotary drive and drive	■	■	■	■	■	■	■	–	adapter
[12]	Shock absorber Y9	Linear shock absorber, self-adjusting at both ends	■	■	■	■	■	■	■	■	65
[13]	Shock absorber, hard Y10	Linear shock absorber, self-adjusting at both ends, hard	–	–	■	–	■	■	■	■	55
[14]	Shock absorber, soft Y14	Linear shock absorber, self-adjusting at both ends, soft	■	■	■	■	■	■	–	–	55
[15]	Shock absorber P	Elastic cushioning elements with metal end position, at both ends	■	■	■	■	■	■	–	–	55
[16]	Shock absorber, external Y12	<ul style="list-style-type: none"> Linear shock absorber, self-adjusting at both ends, external Included in the scope of delivery: [5], 2x [8], [16] 	■	■	■	■	■	■	■	■	55
[17]	Centring sleeve ZBH	For centring attachment (2 pieces included in the scope of delivery of the drive)	■	■	■	■	■	■	■	■	59
[18]	End cap	In conjunction with elastic cushioning element P or shock absorber Y9, Y10, Y14	■	■	■	■	■	■	■	■	–
[19]	End cap	In combination with external shock absorber Y12	■	■	■	■	■	■	■	■	–
[20]	Energy through-feed pneumatic	Enables the quick and easy pneumatic supply of parts connected to the flange (e.g. gripper)	■	■	■	■	■	■	■	■	37
[21]	Energy through-feed pneumatic/electrical	Enables the quick and easy pneumatic/electrical supply of parts connected to the flange (e.g. gripper)	■	■	■	■	■	■	■	■	37
[22]	Connecting cable NEBU	From the energy through-feed to the proximity switch	■	■	■	■	■	■	■	■	63
[23]	Connecting cable NEBU	From the energy through-feed to the controller	■	■	■	■	■	■	■	■	63
[24]	Intermediate position	Possible at 90°	■	■	■	■	■	■	■	–	40
[25]	Connection cap	For the supply ports	■	■	■	■	■	■	■	–	–
[26]	Shock absorber	The cushioning for the intermediate position corresponds to the cushioning for the basic drive. Except in the case of Y12 when shock absorbers Y9 are used	■	■	■	■	■	■	■	–	59
–	One-way flow control valves GRLA	To set the swivel speed	■	■	■	■	■	■	■	■	64

1) The combination of drive shaft [2] and end-position locking E1 [4] is not possible.

Data sheet

Function

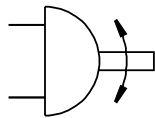

⌀ Diameter
16 ... 63 mm

≡ Torque
1.6 ... 112 Nm

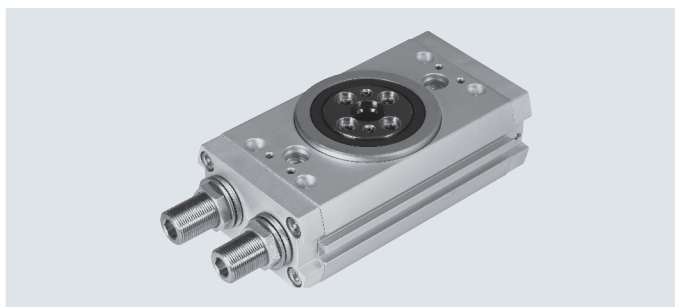

General technical data		16	20	25	32	35	40	50	63
Size		16	20	25	32	35	40	50	63
Design		Gear rack/pinion							
Mode of operation		Double-acting							
Pneumatic connection									
DRRD-...		M5			G1/8		G1/4		G3/8
DRRD-...-PS1		M5							
Type of mounting		With through-hole							
		Via female thread							
Swivel angle									
DRRD-...	[°]	180 (→ page 25)							
DRRD-...-PS1	[°]	90 ±10°							
Cushioning with fixed stop									
DRRD-...-P		Elastic cushioning rings/plates at both ends						-	
DRRD-...-Y9		Linear shock absorber, self-adjusting at both ends							
DRRD-...-Y10 ¹⁾		-	Linear shock absorber, self-adjusting at both ends, hard			-	Linear shock absorber, self-adjusting at both ends, hard		
DRRD-...-Y12		External linear shock absorber, self-adjusting at both ends							
DRRD-...-Y14 ¹⁾		Linear shock absorber, self-adjusting at both ends, soft						-	
Repetition accuracy									
DRRD-...	[°]	< 0.05						≤0.03	
DRRD-...-PS1									
Approached from one end	[°]	0.1						-	
Approached from both ends	[°]	0.7						-	
Axial run-out ²⁾	[mm]	< 0.05							
Max. axial load (static)	[N]	1500	2400	2400	3750	6100	6100	9000	11000
Mounting position		Any							

1) Not in combination with intermediate position DRRD-...-PS1

2) Axial run-out in new condition

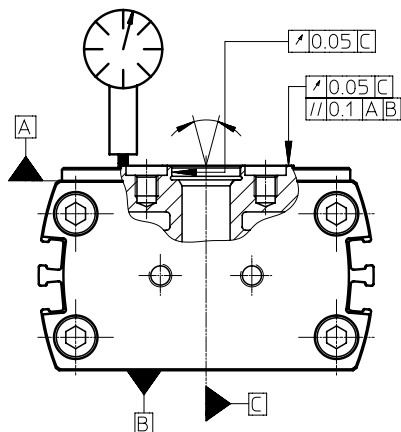

Data sheet

Operating and environmental conditions	
Operating medium	Compressed air to ISO 8573-1:2010 [7:4:4]
Note on operating/pilot medium	Lubricated operation possible (in which case lubricated operation will always be required)
Operating pressure	
DRRD-...	
DRRD-...-P	[bar] 3 ... 8
DRRD-...-Y9/-Y10/-Y12/-Y14	[bar] 2 ... 10
DRRD-...-PS1	
DRRD-...-P	[bar] 4 ... 8
DRRD-...-Y9/-Y12	[bar] 2 ... 10
Ambient temperature	[°C] -10 ... +60
Storage temperature	[°C] -20 ... +60
Degree of protection based on EN 60529	
DRRD-...-SG	IP65

ATEX ¹⁾	
ATEX category for gas	II 2G
Type of ignition protection for gas	Ex h IIC T4 Gb
ATEX category for dust	II 2D
Type of ignition protection for dust	Ex h IIIC T120°C Db
Explosion-proof ambient temperature	-10°C ≤ Ta ≤ +60°C
CE marking (see declaration of conformity)	To EU Explosion Protection Directive (ATEX)

1) Note the ATEX certification of the accessories.

Weights [g]	16	20	25	32	35	40	50	63
Size								
Basic drive with cushioning								
DRRD-...-P	640	839	1349	2815	4510	6070	-	-
DRRD-...-Y9/-Y10/-Y14	650	883	1358	2976	4784	6424	11300	19100
DRRD-...-Y12	757	1132	1705	3760	5425	7160	12450	22400
Energy through-feed (additional)								
DRRD-...-P	320	350	710	920	1090	1470	1950	2250
DRRD-...-P...E...	460	480	720	900	880	1770	2330	2610
Intermediate position (additional)								
DRRD-...-P	502	701	1078	2304	-	-	-	-
DRRD-...-Y9	511	720	1130	2450	3940	4380	8270	-
End-position locking (additional)								
DRRD-...-E1	166	382	370	600	900	900	1610	2380
Sensor mounting, external (additional)								
DRRD-...-R	110	192	192	366	485	485	810	1390

Data sheet

Forces and torques									
Size		16	20	25	32	35	40	50	63
Theoretical torque at 6 bar	[Nm]	1.6	2.4	5.1	10.1	15.8	24.1	53	112
Max. permissible mass moment of inertia									
Rotation from end position to end position									
DRRD-...-P	[kgcm ²]	175	400	900	1500	2500	6700	–	–
DRRD-...-Y9	[kgcm ²]	700	1250	1500	26000	15000	23000	40000	40000
DRRD-...-Y10	[kgcm ²]	–	–	5500	–	45000	67000	200000	420000
DRRD-...-Y12	[kgcm ²]	900	1500	5500	26000	45000	67000	200000	420000
DRRD-...-Y14	[kgcm ²]	100	150	100	2000	2000	23000	–	–
Rotation with intermediate position									
DRRD-...-P	[kgcm ²]	150	300	400	500	–	–	–	–
DRRD-...-Y9	[kgcm ²]	500	900	1500	8000	15000	23000	40000	–
DRRD-...-Y12	[kgcm ²]	500	900	1500	8000	15000	23000	40000	–

Note

If, in the end positions, a torque which exceeds 50% of the theoretical torque acts against the direction of rotation, no exact end position is guaranteed.

This can be avoided by using external shock absorbers (Y12) or a semi-rotary drive with double the torque.

Note

The cushioning for the intermediate position corresponds to the cushioning for the basic drive. Except in the case of cushioning Y12, when shock absorbers Y9 are used.

In combination with cushioning P, the intermediate position is only available for sizes 16 ... 32.

Materials

Sectional view

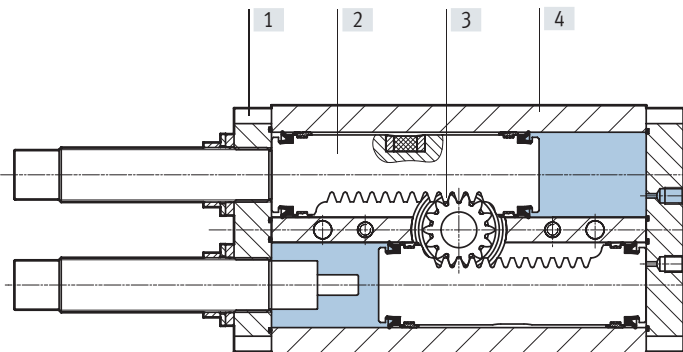

Semi-rotary drive

[1] Cover	Anodised wrought aluminium alloy
[2] Piston	Stainless steel
[3] Flange shaft	Tempered steel
[4] Housing	Smooth-anodised wrought aluminium alloy
Seals	NBR
Piston seal	TPE-U(PU)
Note on materials	RoHS-compliant
	Contains paint-wetting impairment substances

Data sheet

Swivel angle

Fundamentally, the following applies:

Swivel angle $\alpha \geq$ cushioning angle β

Swivel angle $\alpha = 180^\circ + \Delta\alpha_{\text{right}} + \Delta\alpha_{\text{left}}$

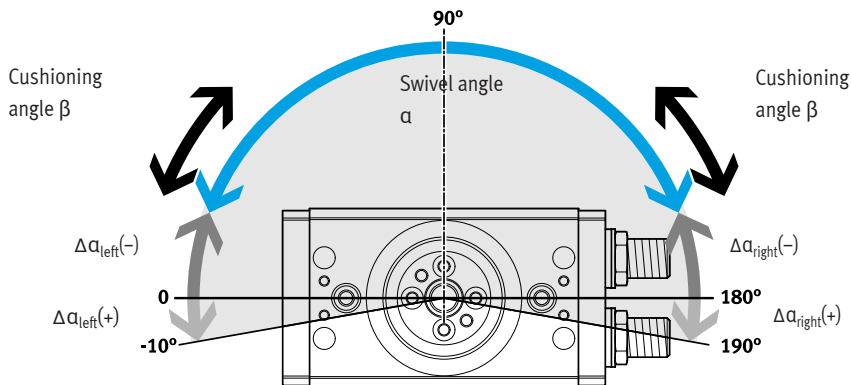

Note
Illustrated position of the flange shaft corresponds to the mid-position (swivel angle 90°)

Size		16	20	25	32	35	40	50	63
Swivel angle α	[°]	180							
Min. swivel angle $\alpha^{1)}$									
DRRD-...P	[°]	36	45	33	33	36	23	-	-
DRRD-...Y9/-Y10/-Y14	[°]	43	72	79	82	85	56	61	48
DRRD-...Y12	[°]	20	24	38	34	34	34	30	34
DRRD-...E1	[°]	60	60	60	55	57	57	62	55
Max. swivel angle $\alpha^{2)}$									
DRRD-...	[°]	200							
DRRD-...Y12	[°]	192	194	190	190	193	193	186	190
Swivel angle adjustment α per side (infinitely adjustable)									
DRRD-...P	[°]	-100 ... +10						-	-
DRRD-...Y9/-Y10/-Y14	[°]	$\geq -100 \dots +10$							
DRRD-...Y12	[°]	-94 ... +6	-85 ... +7	-88 ... +5	-93 ... +5	-86 ... +6.5	-86 ... +3	-91 ... +5	
Cushioning angle β									
DRRD-...P	[°]	36	45	33	33	36	23	-	-
DRRD-...Y9/-Y10/-Y14	[°]	43	72	79	82	85	56	61	48
DRRD-...Y12	[°]	10	12	19	17	17	17	15	17

1) It is possible to set smaller swivel angles. However, this reduces the cushioning energy

2) The max. swivel angle is reduced by approx. 10° in combination with the external sensor mounting

Swivel angle adjustment

Clockwise direction of rotation:

- Swivel angle decreases

Anticlockwise direction of rotation:

- Swivel angle increases

The swivel angle is adjusted via the cushioning elements using an Allen key. Any reduction in the swivel angle should preferably be evenly split between the two end positions.

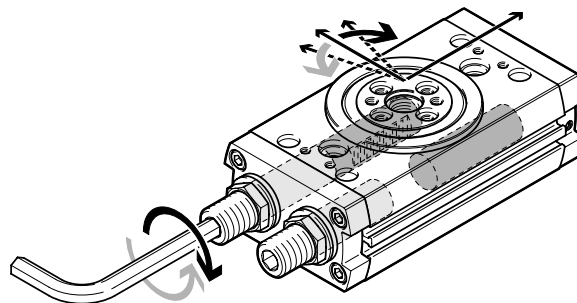

Swivel angle adjustment of the intermediate position → page 40

Data sheet

Max. permissible mass moment of inertia J at the flange shaft as a function of swivel time t (at room temperature and an operating pressure of 6 bar)

Size 16 with cushioning P/Y9/Y14
Swivel angle 90°

Swivel angle 180°

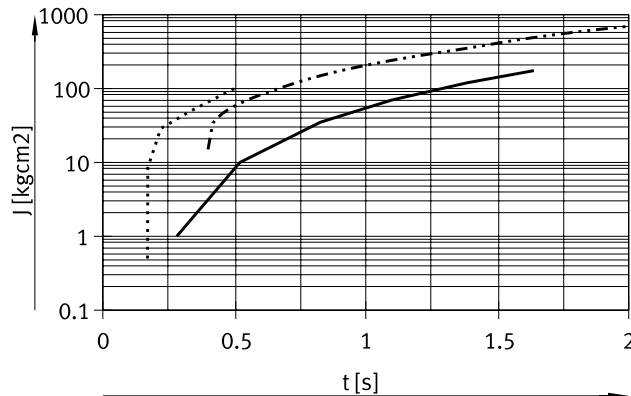
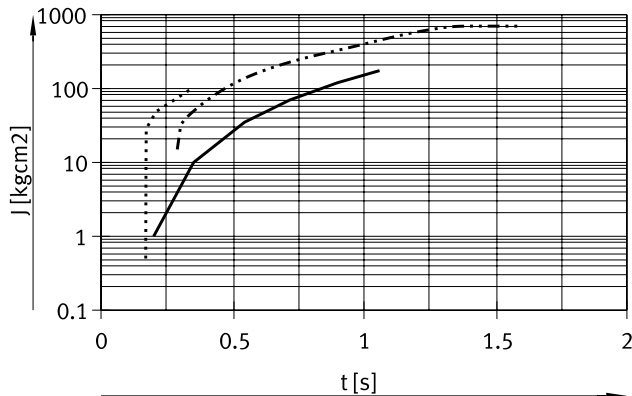

- | | | | |
|-------|-----------------------|--------|---------------------------------|
| — | DRRD-16-...-P (90°) | Ranges | → 1 ... 175 kgcm ² |
| ····· | DRRD-16-...-Y9 (90°) | | → 15 ... 700 kgcm ² |
| - - - | DRRD-16-...-Y14 (90°) | | → 0.5 ... 100 kgcm ² |

- | | | | |
|-------|------------------------|--------|---------------------------------|
| — | DRRD-16-...-P (180°) | Ranges | → 1 ... 175 kgcm ² |
| ····· | DRRD-16-...-Y9 (180°) | | → 15 ... 700 kgcm ² |
| - - - | DRRD-16-...-Y14 (180°) | | → 0.5 ... 100 kgcm ² |

Size 20 with cushioning P/Y9/Y14
Swivel angle 90°

Swivel angle 180°

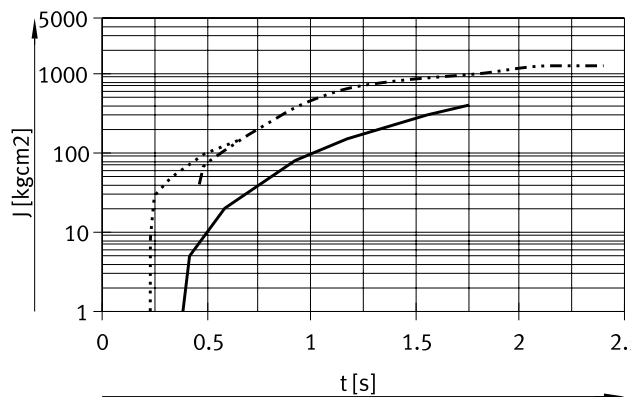
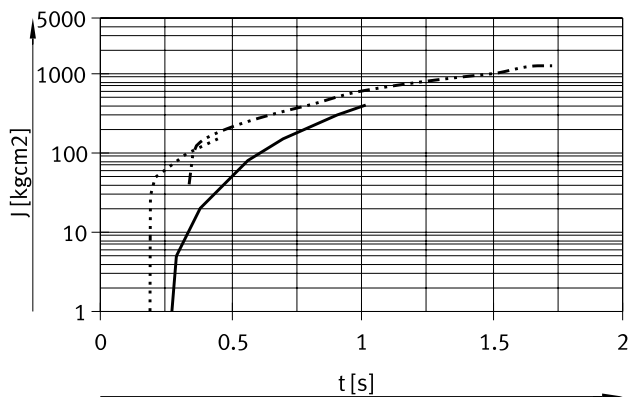

- | | | | |
|-------|-----------------------|--------|---------------------------------|
| — | DRRD-20-...-P (90°) | Ranges | → 1 ... 400 kgcm ² |
| ····· | DRRD-20-...-Y9 (90°) | | → 40 ... 1250 kgcm ² |
| - - - | DRRD-20-...-Y14 (90°) | | → 1 ... 150 kgcm ² |

- | | | | |
|-------|------------------------|--------|---------------------------------|
| — | DRRD-20-...-P (180°) | Ranges | → 1 ... 400 kgcm ² |
| ····· | DRRD-20-...-Y9 (180°) | | → 40 ... 1250 kgcm ² |
| - - - | DRRD-20-...-Y14 (180°) | | → 1 ... 150 kgcm ² |

Data sheet

**Max. permissible mass moment of inertia J at the flange shaft as a function of swivel time t
(at room temperature and an operating pressure of 6 bar)**

Size 25 with cushioning P/Y9/Y10/Y14

Swivel angle 90°

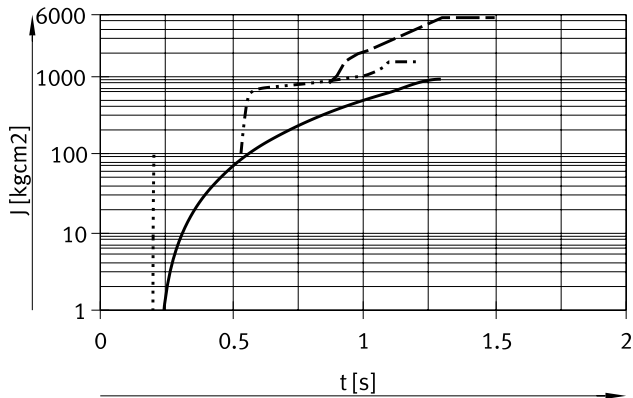

—	DRRD-25-...-P (90°)	Ranges	→ 1 ... 900 kgcm ²
·····	DRRD-25-...-Y9 (90°)		→ 100 ... 1500 kgcm ²
- - -	DRRD-25-...-Y10 (90°)		→ 800 ... 5500 kgcm ²
- · - · -	DRRD-25-...-Y14 (90°)		→ 1 ... 100 kgcm ²

Swivel angle 180°

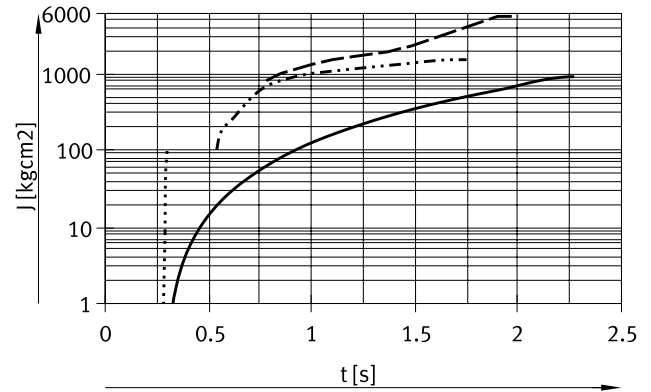

—	DRRD-25-...-P (180°)	Ranges	→ 1 ... 900 kgcm ²
·····	DRRD-25-...-Y9 (180°)		→ 100 ... 1500 kgcm ²
- - -	DRRD-25-...-Y10 (180°)		→ 800 ... 5500 kgcm ²
- · - · -	DRRD-25-...-Y14 (180°)		→ 1 ... 100 kgcm ²

Size 32 with cushioning P/Y9/Y14

Swivel angle 90°

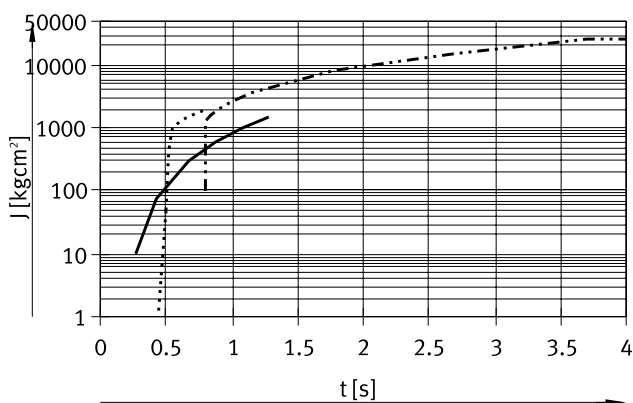

—	DRRD-32-...-P (90°)	Ranges	→ 10 ... 1500 kgcm ²
·····	DRRD-32-...-Y9 (90°)		→ 100 ... 26000 kgcm ²
- - -	DRRD-32-...-Y14 (90°)		→ 1 ... 2000 kgcm ²

Swivel angle 180°

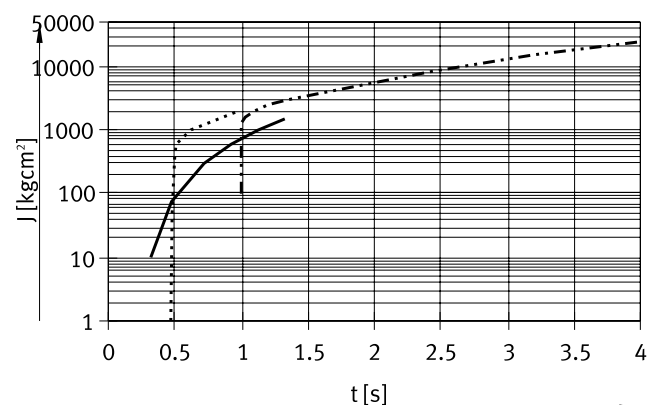

—	DRRD-32-...-P (180°)	Ranges	→ 10 ... 1500 kgcm ²
·····	DRRD-32-...-Y9 (180°)		→ 100 ... 26000 kgcm ²
- - -	DRRD-32-...-Y14 (180°)		→ 1 ... 2000 kgcm ²

Data sheet

Max. permissible mass moment of inertia J at the flange shaft as a function of swivel time t (at room temperature and an operating pressure of 6 bar)

Size 35 with cushioning P/Y9/Y10/Y14

Swivel angle 90°

Swivel angle 180°

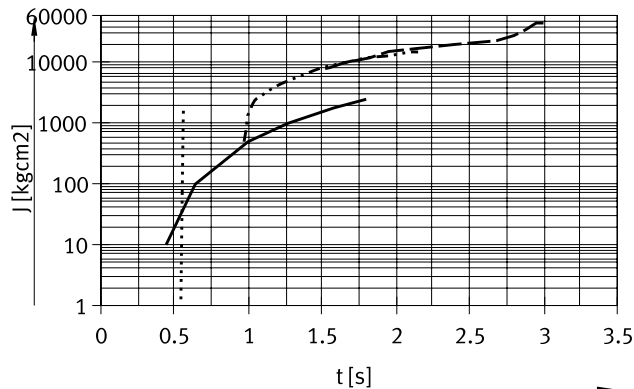
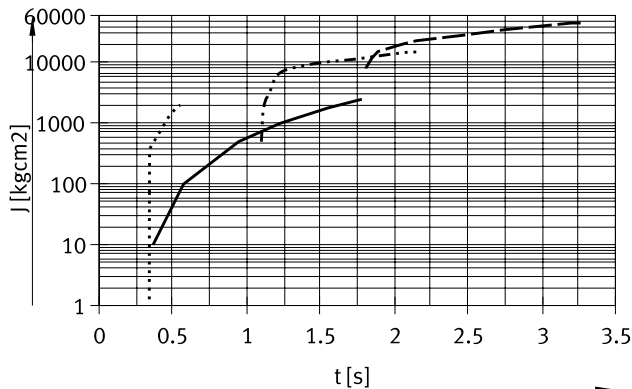

- | | | | |
|-----------|-----------------------|--------|------------------------------------|
| — | DRRD-35-...-P (90°) | Ranges | → 10 ... 2500 kgcm ² |
| ····· | DRRD-35-...-Y9 (90°) | | → 500 ... 15000 kgcm ² |
| - - - - | DRRD-35-...-Y10 (90°) | | → 8000 ... 45000 kgcm ² |
| - · - · - | DRRD-35-...-Y14 (90°) | | → 1 ... 2000 kgcm ² |

- | | | | |
|-----------|------------------------|--------|------------------------------------|
| — | DRRD-35-...-P (180°) | Ranges | → 10 ... 2500 kgcm ² |
| ····· | DRRD-35-...-Y9 (180°) | | → 500 ... 1500 kgcm ² |
| - - - - | DRRD-35-...-Y10 (180°) | | → 8000 ... 45000 kgcm ² |
| - · - · - | DRRD-35-...-Y14 (180°) | | → 1 ... 2000 kgcm ² |

Size 40 with cushioning P/Y9/Y10/Y14

Swivel angle 90°

Swivel angle 180°

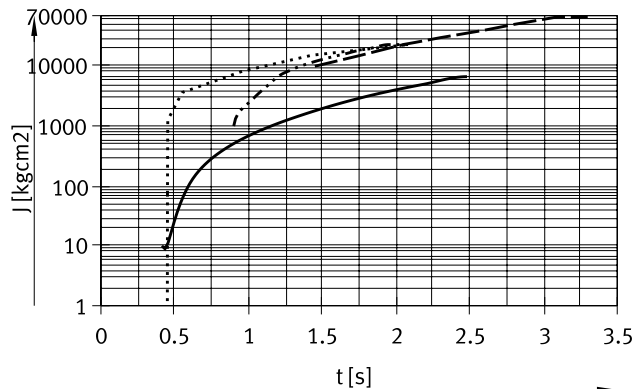
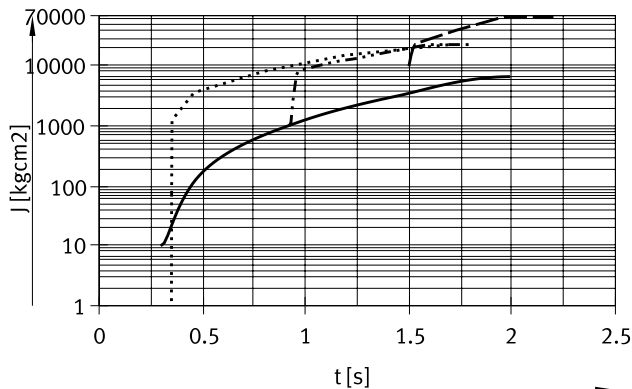

- | | | | |
|-----------|-----------------------|--------|-------------------------------------|
| — | DRRD-40-...-P (90°) | Ranges | → 10 ... 6700 kgcm ² |
| ····· | DRRD-40-...-Y9 (90°) | | → 1000 ... 23000 kgcm ² |
| - - - - | DRRD-40-...-Y10 (90°) | | → 10000 ... 67000 kgcm ² |
| - · - · - | DRRD-40-...-Y14 (90°) | | → 1 ... 23000 kgcm ² |

- | | | | |
|-----------|------------------------|--------|-------------------------------------|
| — | DRRD-40-...-P (180°) | Ranges | → 10 ... 6700 kgcm ² |
| ····· | DRRD-40-...-Y9 (180°) | | → 1000 ... 23000 kgcm ² |
| - - - - | DRRD-40-...-Y10 (180°) | | → 10000 ... 67000 kgcm ² |
| - · - · - | DRRD-40-...-Y14 (180°) | | → 1 ... 23000 kgcm ² |

Data sheet

**Max. permissible mass moment of inertia J at the flange shaft as a function of swivel time t
(at room temperature and an operating pressure of 6 bar)**

Size 50 with cushioning Y9/Y10

Swivel angle 90°

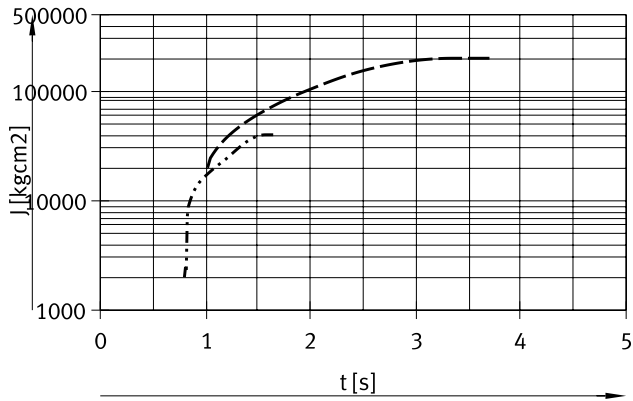

	Ranges
..... DRRD-50-...-Y9 (90°)	→ 2000 ... 40000 kgcm ²
----- DRRD-50-...-Y10 (90°)	→ 20000 ... 200000 kgcm ²

Swivel angle 180°

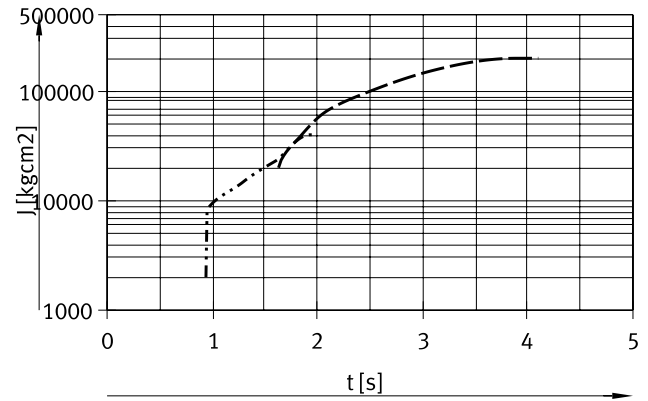

	Ranges
..... DRRD-50-...-Y9 (180°)	→ 2000 ... 40000 kgcm ²
----- DRRD-50-...-Y10 (180°)	→ 20000 ... 200000 kgcm ²

Size 63 with cushioning Y9/Y10

Swivel angle 90°

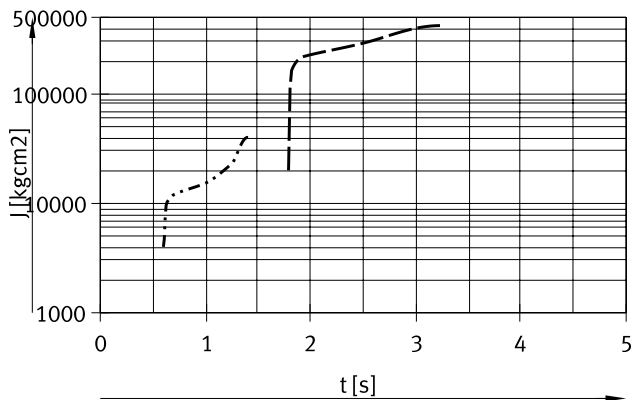

	Ranges
..... DRRD-63-...-Y9 (90°)	→ 4000 ... 40000 kgcm ²
----- DRRD-63-...-Y10 (90°)	→ 20000 ... 420000 kgcm ²

Swivel angle 180°

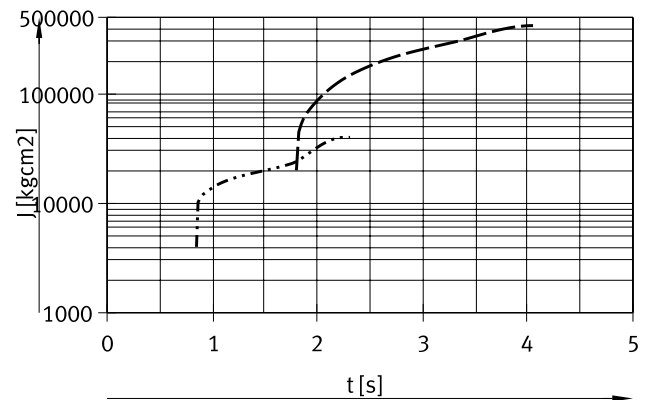

	Ranges
..... DRRD-63-...-Y9 (180°)	→ 4000 ... 40000 kgcm ²
----- DRRD-63-...-Y10 (180°)	→ 20000 ... 420000 kgcm ²

Data sheet

Max. permissible mass moment of inertia J at the flange shaft as a function of swivel time t (at room temperature and an operating pressure of 6 bar)

Size 16 with cushioning Y12
Swivel angle 90°/180°

Size 20 with cushioning Y12

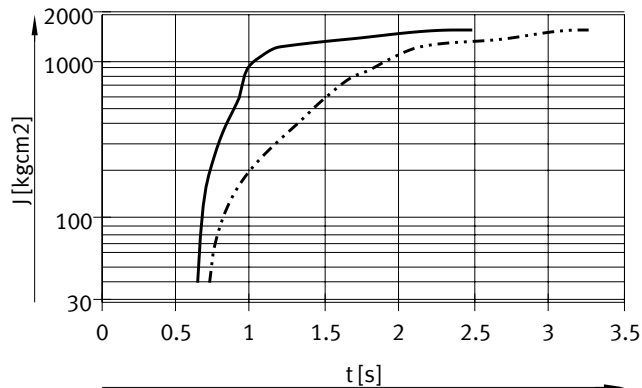
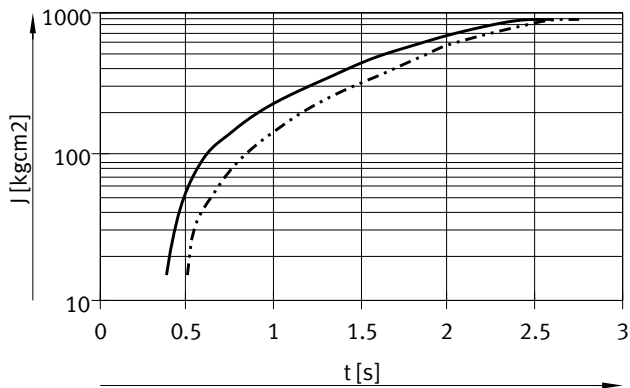

— DRRD-16-...-Y12 (90°) → 15 ... 900 kgcm²
 - - - DRRD-16-...-Y12 (180°) → 15 ... 900 kgcm²

— DRRD-20-...-Y12 (90°) → 40 ... 1600 kgcm²
 - - - DRRD-20-...-Y12 (180°) → 40 ... 1600 kgcm²

Size 25 with cushioning Y12
Swivel angle 90°/180°

Size 32 with cushioning Y12

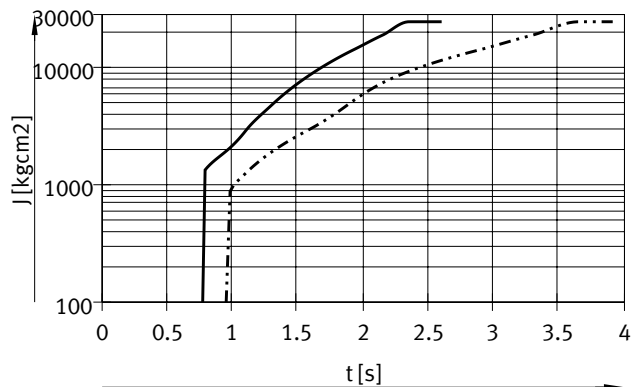
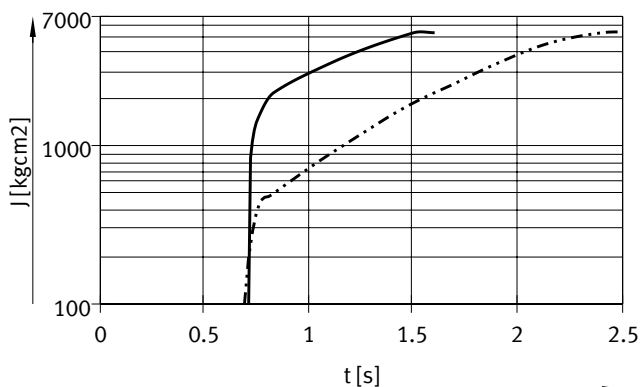

— DRRD-25-...-Y12 (90°) → 100 ... 5500 kgcm²
 - - - DRRD-25-...-Y12 (180°) → 100 ... 5500 kgcm²

— DRRD-32-...-Y12 (90°) → 100 ... 26000 kgcm²
 - - - DRRD-32-...-Y12 (180°) → 100 ... 26000 kgcm²

Data sheet

Max. permissible mass moment of inertia J at the flange shaft as a function of swivel time t (at room temperature and an operating pressure of 6 bar)

Size 35 with cushioning Y12
Swivel angle 90°/180°

Size 40 with cushioning Y12

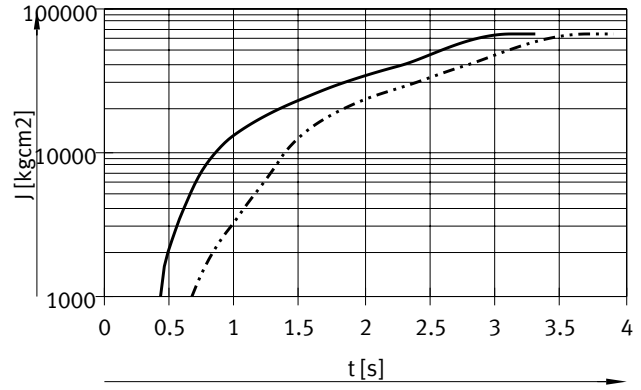
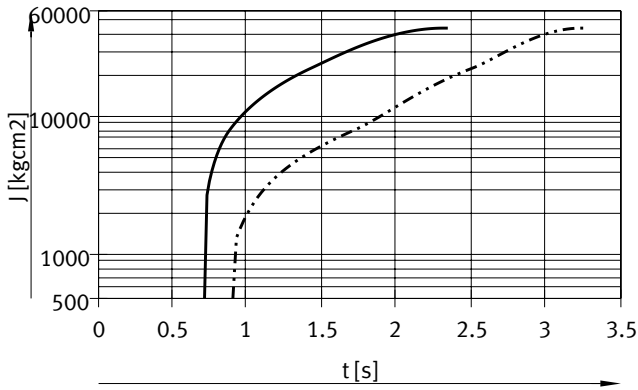

— DRRD-35-...-Y12 (90°) → 500 ... 45000 kgcm²
 - - - DRRD-35-...-Y12 (180°) → 500 ... 45000 kgcm²

— DRRD-40-...-Y12 (90°) → 1000 ... 67000 kgcm²
 - - - DRRD-40-...-Y12 (180°) → 1000 ... 67000 kgcm²

Size 50 with cushioning Y12
Swivel angle 90°/180°

Size 63 with cushioning Y12

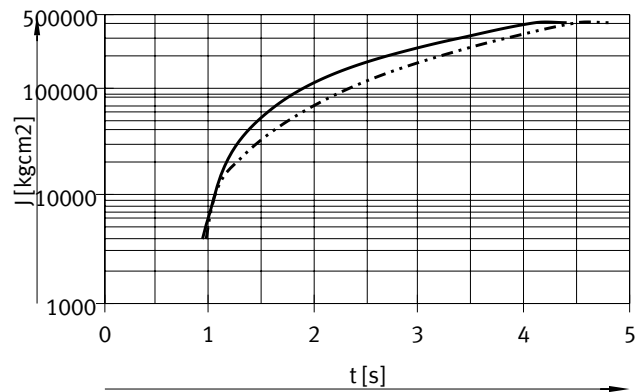
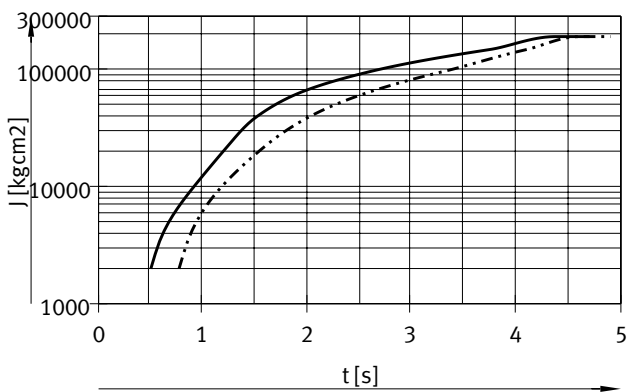

— DRRD-50-...-Y12 (90°) → 2000 ... 200000 kgcm²
 - - - DRRD-50-...-Y12 (180°) → 2000 ... 200000 kgcm²

— DRRD-63-...-Y12 (90°) → 4000 ... 420000 kgcm²
 - - - DRRD-63-...-Y12 (180°) → 4000 ... 420000 kgcm²

Data sheet

Max. dynamic load capacity at the flange shaft

The zero point for dimension Z is always the flange level of the basic drive, independently of the attachments (flange module).

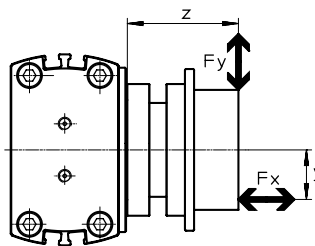
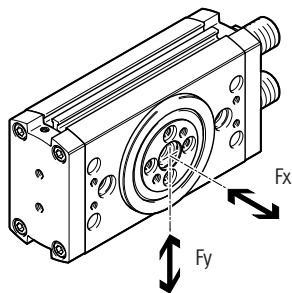

The following equation applies to combined loads (axial and radial):

$$\frac{F_y(z)}{F_{y\max.}(z)} + \frac{F_x(y)}{F_{x\max.}(y)} \leq 1$$

Max. dynamic radial force F_y as a function of distance z
Size 16/20

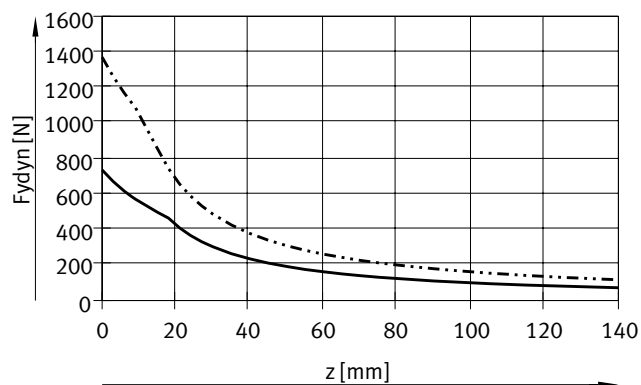

— DRRD-16
- - - DRRD-20

Size 25/32

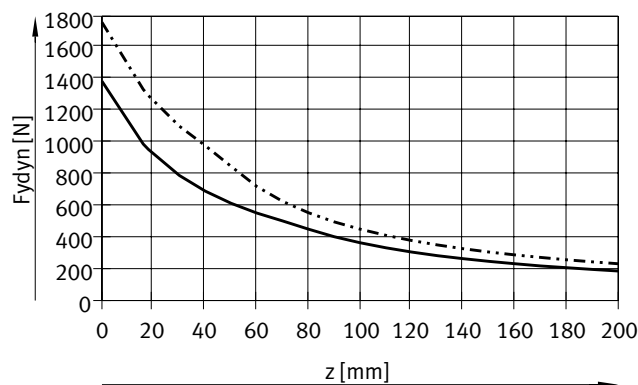

— DRRD-25
- - - DRRD-32

Size 35/40

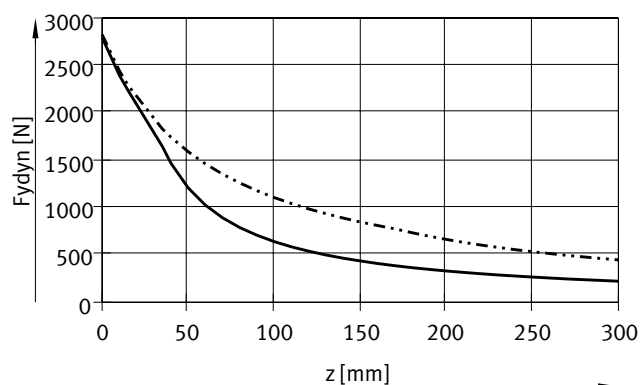

— DRRD-35
- - - DRRD-40

Size 50/63

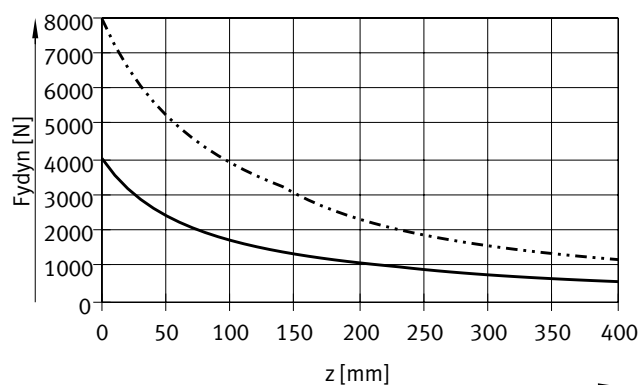

— DRRD-50
- - - DRRD-63

Data sheet

Max. dynamic load capacity at the flange shaft

The zero point for dimension Z is always the flange level of the basic drive, independently of the attachments (flange module).

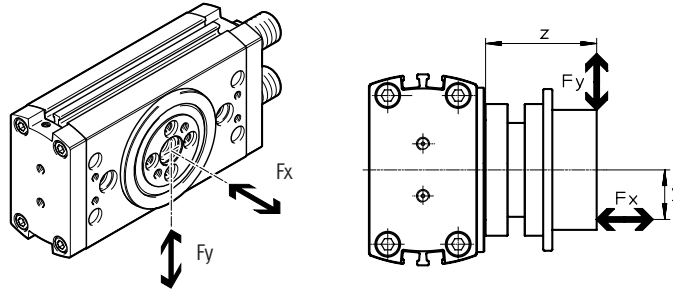

The following equation applies to combined loads (axial and radial):

$$\frac{F_{y(z)}}{F_{y \max. (z)}} + \frac{F_{x(y)}}{F_{x \max. (y)}} \leq 1$$

Max. dynamic radial force F_x as a function of distance y
Size 16/20

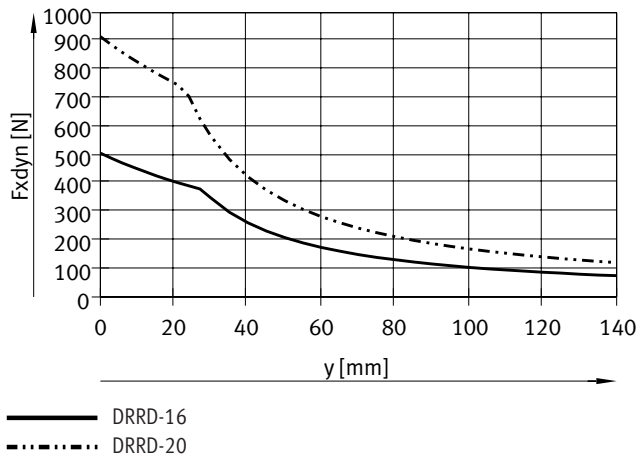

Size 25/32

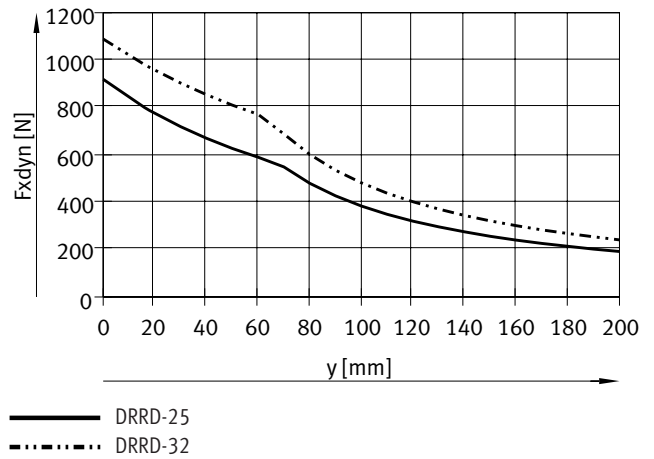

Size 35/40

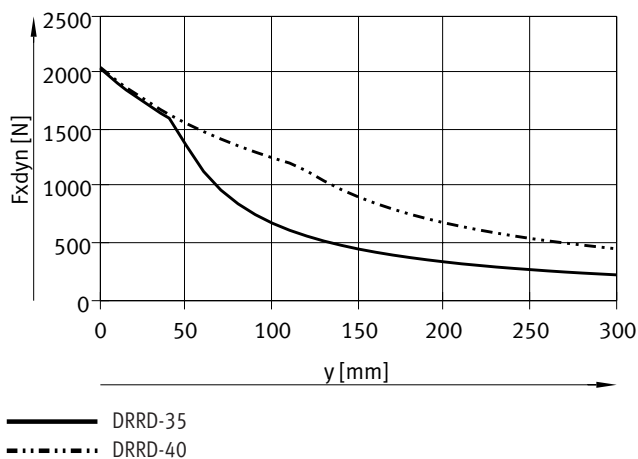

Size 50/63

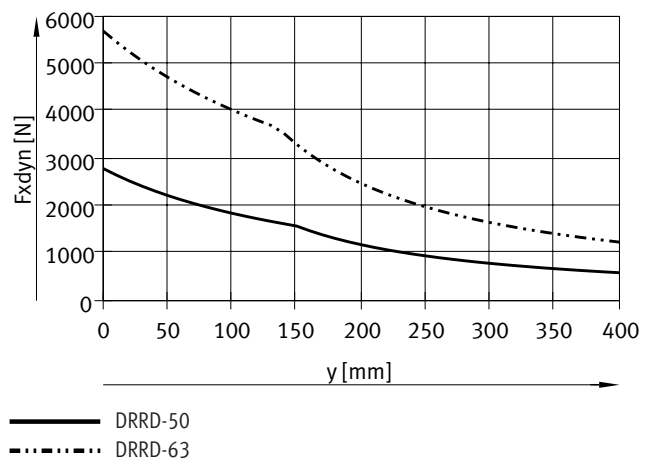

Data sheet

Max. static load capacity at the flange shaft

The zero point for dimension Z is always the flange level of the basic drive, independently of the attachments (flange module).

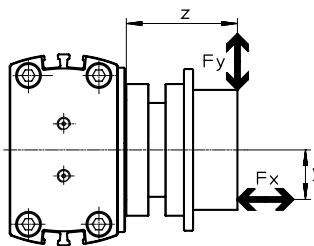
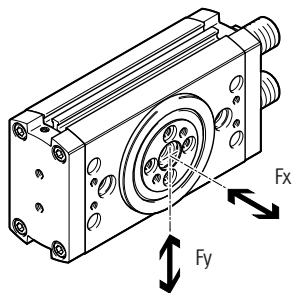

The following equation applies to combined loads (axial and radial):

$$\frac{F_y(z)}{F_{y\max.}(z)} + \frac{F_x(y)}{F_{x\max.}(y)} \leq 1$$

Max. static radial force F_y as a function of distance z

Size 16/20

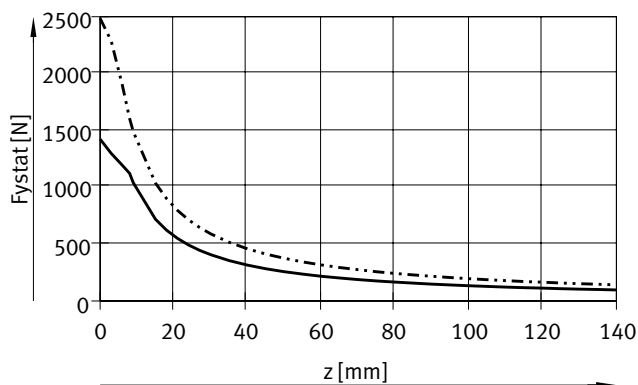

— DRRD-16
- - - DRRD-20

Size 25/32

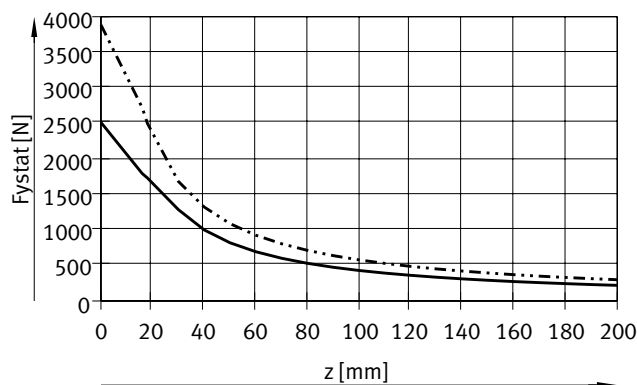

— DRRD-25
- - - DRRD-32

Size 35/40

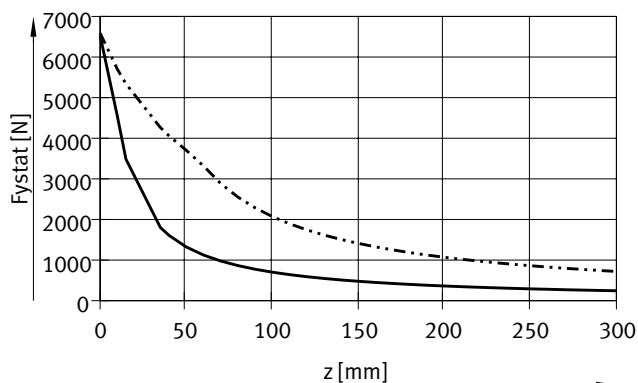

— DRRD-35
- - - DRRD-40

Size 50/63

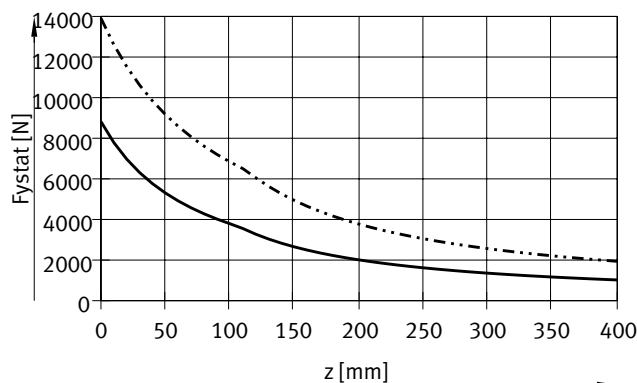

— DRRD-50
- - - DRRD-63

Data sheet

Max. static load capacity at the flange shaft

The zero point for dimension Z is always the flange level of the basic drive, independently of the attachments (flange module).

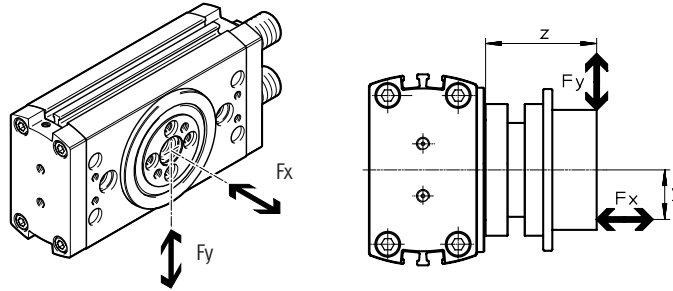

The following equation applies to combined loads (axial and radial):

$$\frac{F_y(z)}{F_{y \max. (z)}} + \frac{F_x(y)}{F_{x \max. (y)}} \leq 1$$

Max. static axial force F_x as a function of distance y
Size 16/20

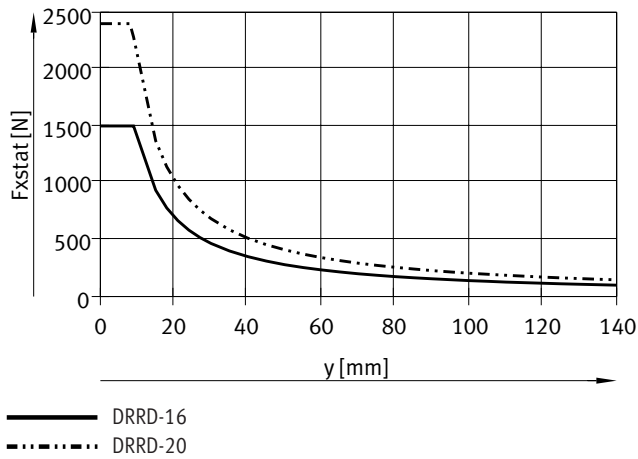

Size 25/32

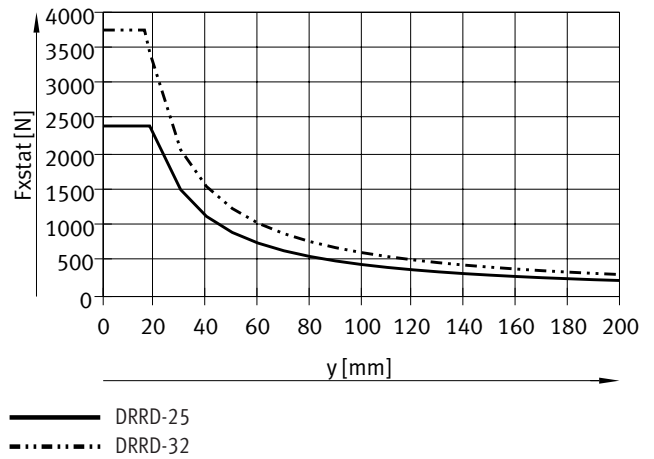

Size 35/40

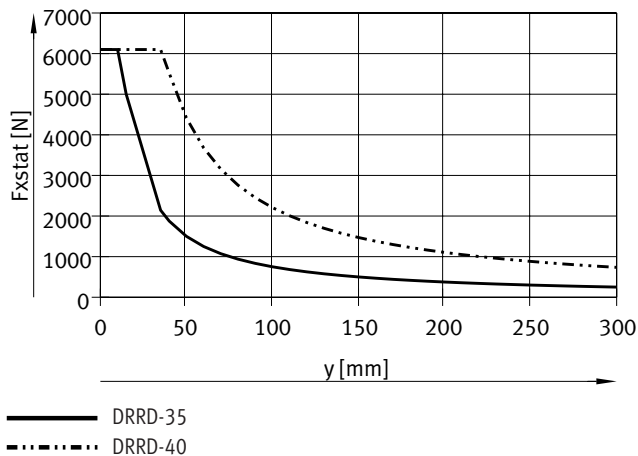

Size 50/63

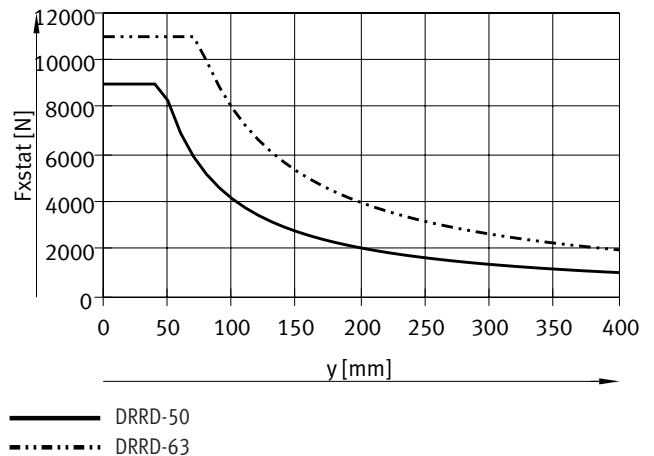

Data sheet

Max. load capacity on the drive shaft (DARF-Q11)

Max. radial forces F_y / axial forces F_x / bending moment M

- For the radial forces F_y , the limits of the flange shaft → page 32/34 and max. bending moment of the drive shaft apply → table below.
- The bending moment represents the load limit of the drive shaft and must not be exceeded.
- The zero point for dimension z is always the flange level of the basic drive, independently of the attachments (flange module).
- The axial force represents an additional load.

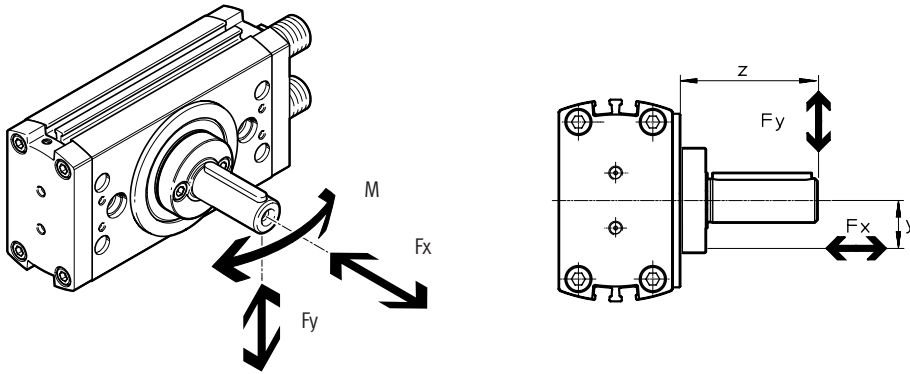

Size		16	20	25	32	35	40
Axial force F_x	[N]	625	625	625	900	900	2400
Bending moment M	[Nm]	13.5	14.4	34.4	63	63	84

Data sheet

Energy through-feed DRRD-...-P...E...

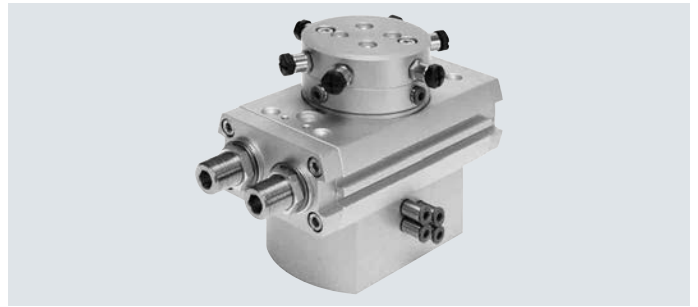

Function

The energy through-feed can be used to transfer electrical signals or compressed air through the hollow shaft.

Advantages

- Fast and easy supply of the parts connected to the flange (e.g. gripper)
- Tubing and electrical cables are not damaged by the rotation
- Two variants available:
 - Pneumatic
 - Pneumatic and electrical
- Different number of connections depending on the size

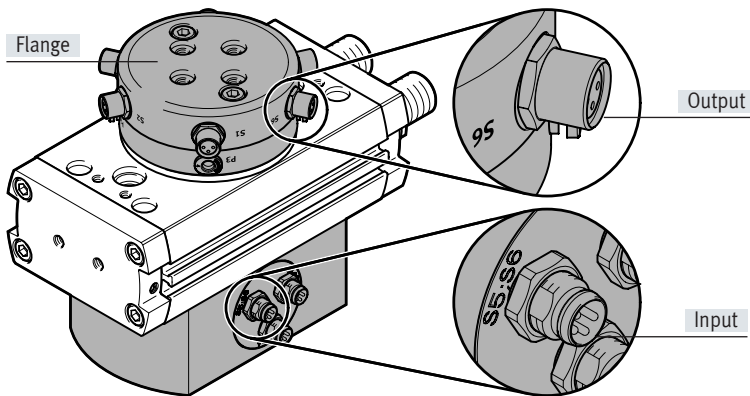

Note
Only connecting cables with straight connectors can be used (→ page 63).

Technical data

Size	16/20		25/32/35		40/50/63	
Variant	Pneumatic	Pneumatic/ electrical	Pneumatic	Pneumatic/ electrical	Pneumatic	Pneumatic/ electrical
Order code	P2	P2E2	P4	P4E6	P8	P8E8
Pneumatic						
Number of pneumatic ducts	2	2	4	4	8	8
Tubing O.D.	4					
Operating pressure per duct [bar]	-0.85 ... 8					
Connection	M5					
Flow rate per duct [l/min]	86				33	
Electric						
Number of electrical signals	–	2	–	6	–	8
Rated voltage [V DC]	–	30	–	30	–	30
Max. current ¹⁾ [A]	1.5					
Connection	M8				M12	

1) The positive and negative lines of all electrical connections are connected together. The combined maximum peak current for this common positive and negative line is also 1.5 A.

Note
Also approved for vacuum operation.

Data sheet

DRRD-...-P...E... – Energy through-feed

Pin allocation

Size 16/20

Input Plug M8				Output M8 socket			
Designation	Signals	Pin ¹⁾	Circuit diagram	Circuit diagram	Pin ¹⁾	Signals	Designation
S1	+ - Sig 1	1			1 3 4	+ - Sig 1	S1
		3					
		4					
S2	+ - Sig 2	1			1 3 4	+ - Sig 2	S2
		3					
		4					

1) Pin 1 (+) and Pin 3 (-) are connected to each other between plugs S1 and S2. Unused plugs and sockets should therefore be protected with the cover caps.

Size 25/32/35



Input Plug M8				Output M8 socket			
Designation	Signals	Pin ¹⁾	Circuit diagram	Circuit diagram	Pin ¹⁾	Signals	Designation
S1;S2	+ Sig 2 - Sig 1	1			1 3 4	+ - Sig 1	S1
		2					
		3					
S3;S4	+ Sig 4 - Sig 3	1			1 3 4	+ - Sig 3	S3
		2					
		3					
S5;S6	+ Sig 6 - Sig 5	1			1 3 4	+ - Sig 5	S5
		2					
		3					
S5;S6	+ Sig 6 - Sig 5	1			1 3 4	+ - Sig 6	S6
		2					
		3					

1) Pin 1 (+) and Pin 3 (-) are connected to each other between plugs S1 ... S6. Unused plugs and sockets should therefore be protected with the cover caps.

Data sheet

DRRD-...-P...E... – Energy through-feed

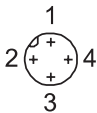
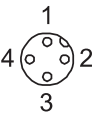
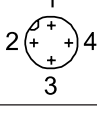
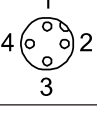
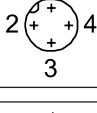
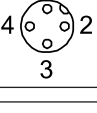
Size 40/50/63

Input M12 plug				Output M12 socket			
Designation	Signals	Pin ¹⁾	Circuit diagram	Circuit diagram	Pin ¹⁾	Signals	Designation
S1;S2	+ Sig 2 - Sig 1	1 2 3 4			1 2 3 4	+ Sig 2 - Sig 1	S1;S2
S3;S4	+ Sig 4 - Sig 3	1 2 3 4			1 2 3 4	+ Sig 4 - Sig 3	S3;S4
S5;S6	+ Sig 6 - Sig 5	1 2 3 4			1 2 3 4	+ Sig 6 - Sig 5	S5;S6
S7;S8	+ Sig 8 - Sig 7	1 2 3 4			1 2 3 4	+ Sig 8 - Sig 7	S7;S8

1) Pin 1 (+) and Pin 3 (-) are connected to each other between plugs S1 ... S8. Unused plugs and sockets should therefore be protected with the cover caps.

Data sheet

Intermediate position DRRD-...-PS1



Function

The intermediate-position module enables an additional position to be set, at half of the nominal rotation angle (90°).

A piston with two screwed-in guide systems is supplied with compressed air and moves the gear racks of the unpressurised semi-rotary drive until both pistons rest on the plungers positioned in the guide systems and are held in this position. The movement is cushioned using a shock absorber.

To move to the other end position, the semi-rotary drive is pressurised with compressed air. The piston of the basic drive thus moves the entire intermediate-position piston back into its initial position.

Characteristics

- Setting range: $90^\circ \pm 10^\circ$
- Cushioning variants: P, Y9
- Can be approached and travelled through from both end positions
- Position sensing of the intermediate position possible

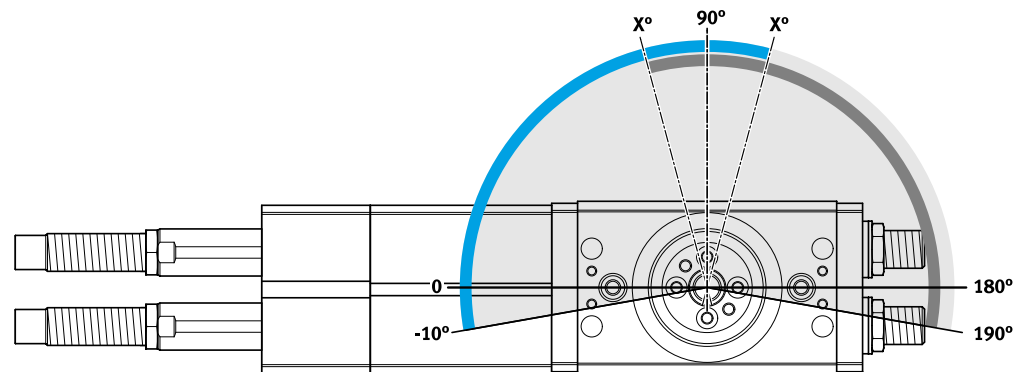

Setting the swivel speed

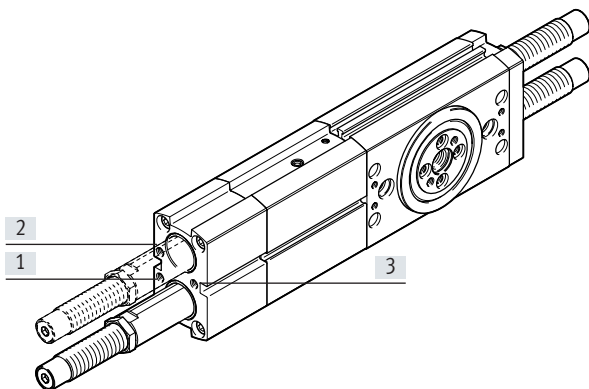

Semi-rotary drive and intermediate-position module must only be operated with controlled air flow. The flow control should be connected as close as possible to the semi-rotary drive (e.g. one-way flow control valve GRLA-...) → page 64.

In the event of pressure failure, the payload may hit an end position in an uncontrolled manner. In order to prevent this, piloted check valves HGL or an air reservoir VZS are recommended → page 64.

The following movements are adjusted using the supply ports [1] and [2]: end position → intermediate position

Both directions can be adjusted separately from each other.

The following movement is adjusted via supply port [3]:

Intermediate position → end position

Both directions are set simultaneously.

Data sheet

DRRD-...-PS1 – Intermediate position

Swivel angle adjustment

By pushing the shock absorber as far as the stop, the flange shaft of the semi-rotary drive rotates into the intermediate position.

In delivered state, the intermediate position is set to 90°. By screwing in or

unscrewing the shock absorbers, the swivel angle can be adjusted by $\pm 10^\circ$.

If the setting dimension X_{\max} is exceeded, the shock absorber can no longer completely cushion the movement.

If the setting dimension X_{\min} is not reached, the shock absorber not only

cushions the intermediate position, but also the end position of the semi-rotary drive.

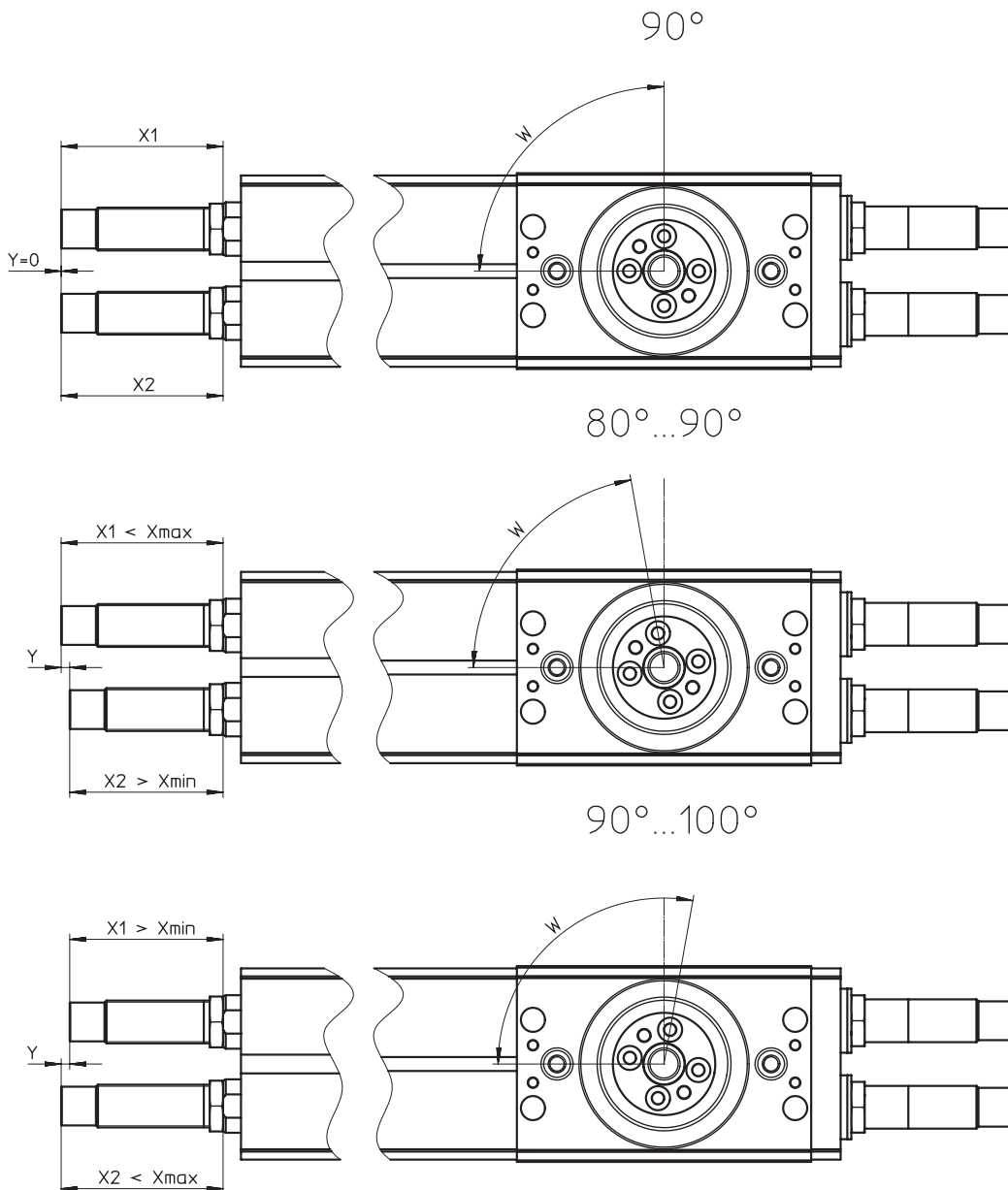

Size		16	20	25	32	35	40	50	
Setting dimension X									
DRRD-...-P									
X_{\min}	[mm]	7.7	14.9	14.2	12.5	-	-	-	
X_{\max}	[mm]	10.1	17.8	20.6	23.2	-	-	-	
DRRD-...-Y9									
X_{\min}	[mm]	29.6	41.8	56.9	70.3	88.6	86.7	114	
X_{\max}	[mm]	32	44.5	60.4	78.5	96.2	92.7	128	
Dimension Y for 10° change in the swivel angle		[mm]	2.3	2.4	3.2	3.7	3.7	5.6	8

Data sheet

DRRD-...-PS1 – Intermediate position

Control variants

Circuit diagram

[1] With 1x 5/3-way valve and 1x 3/2-way valve

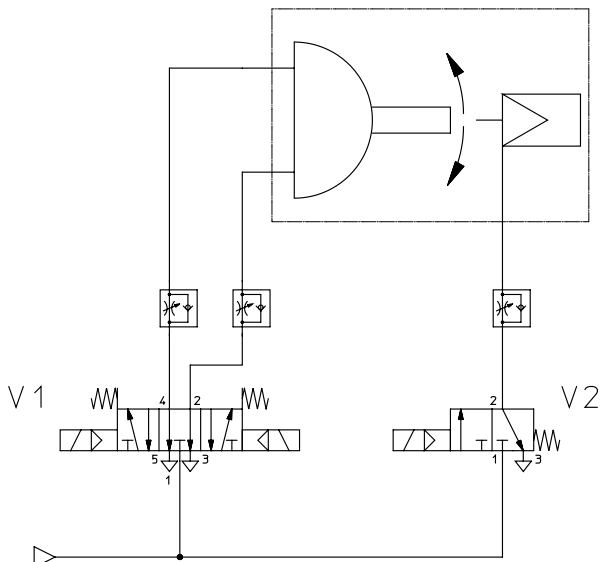

Control sequence

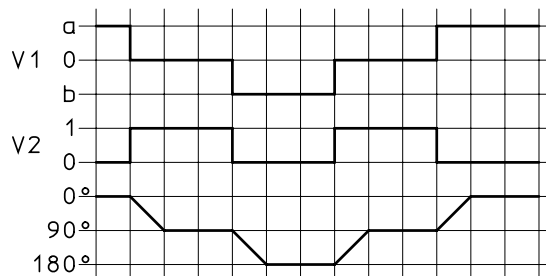

[2] With 3x 3/2-way valves

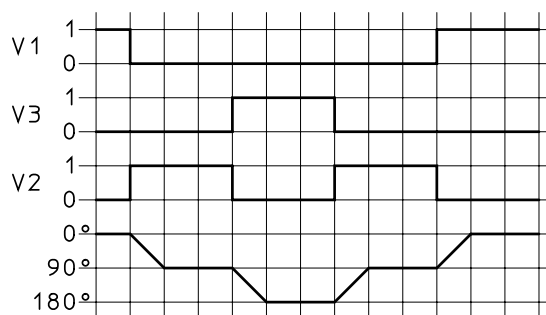
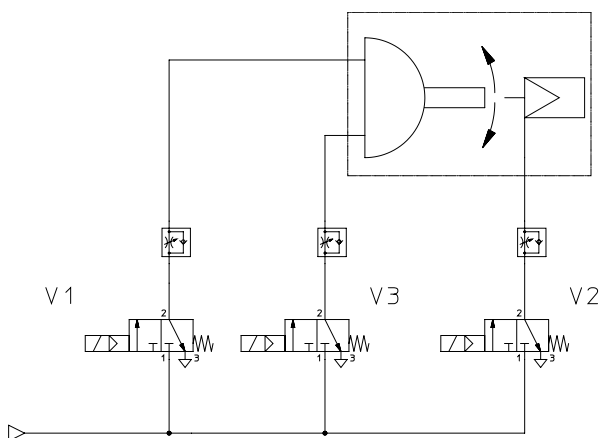

[3] With 1x 5/3-way valve and 3x 3/2-way valve

The exhaust air flow control valves for the basic drive can be adjusted separately here.

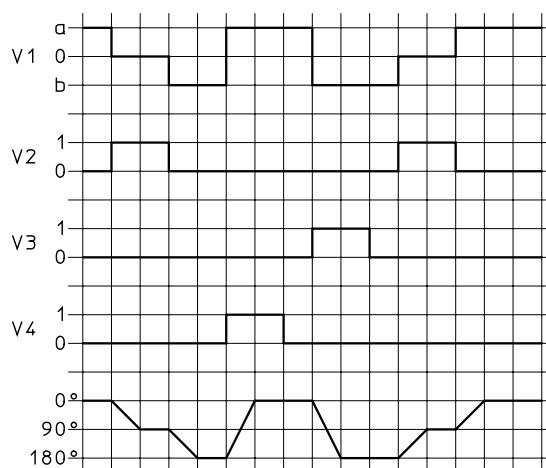
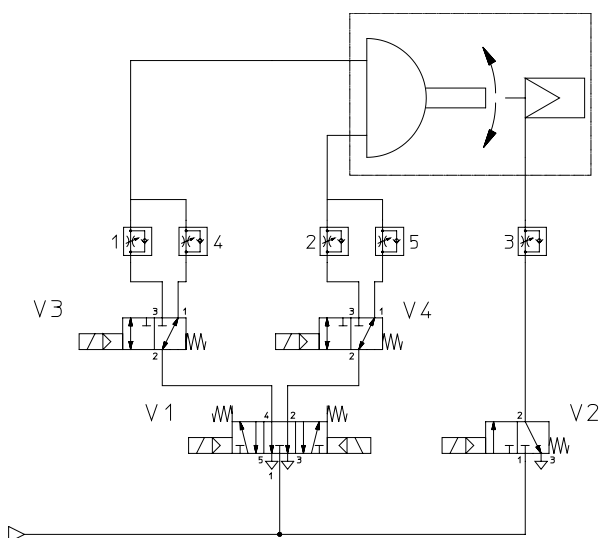

Data sheet

DRRD-...-PS1 – Intermediate position
 Max. permissible mass moment of inertia J at the flange shaft as a function of swivel time t
 (at room temperature and an operating pressure of 6 bar)

Size 16

End position to intermediate position

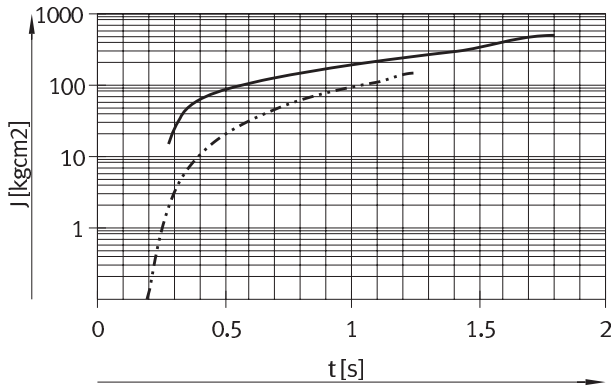

— DRRD-16-...-Y9-PS1 → 15 ... 500 kgcm²
 - · - · - · DRRD-16-P-PS1 → 0 ... 150 kgcm²

Intermediate position to end position

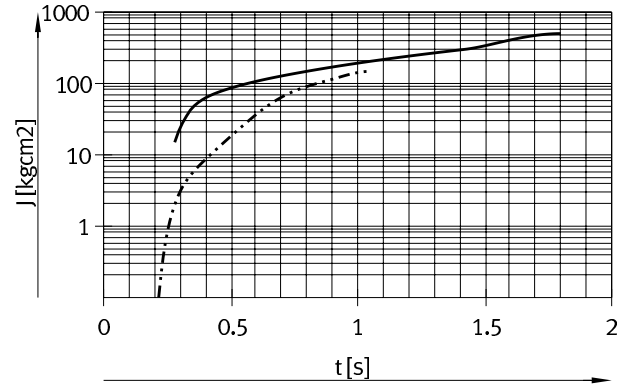

— DRRD-16-...-Y9-PS1 → 15 ... 500 kgcm²
 - · - · - · DRRD-16-P-PS1 → 0 ... 150 kgcm²

Size 20

End position to intermediate position

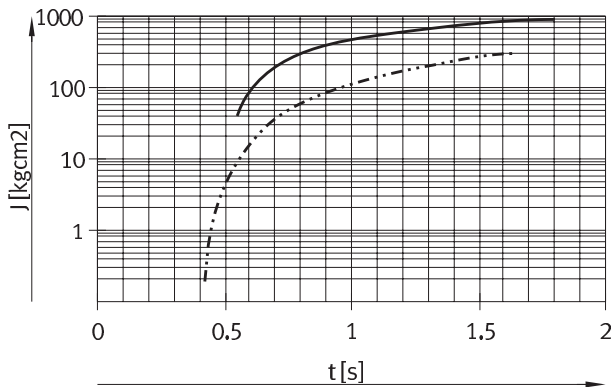

— DRRD-20-...-Y9-PS1 → 40 ... 900 kgcm²
 - · - · - · DRRD-20-P-PS1 → 0 ... 300 kgcm²

Intermediate position to end position

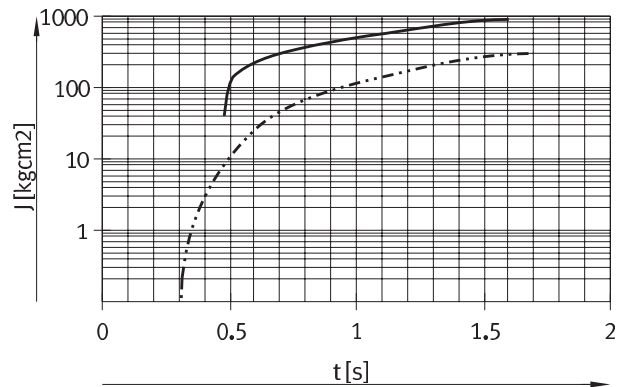

— DRRD-20-...-Y9-PS1 → 40 ... 900 kgcm²
 - · - · - · DRRD-20-P-PS1 → 0 ... 300 kgcm²

Size 25

End position to intermediate position

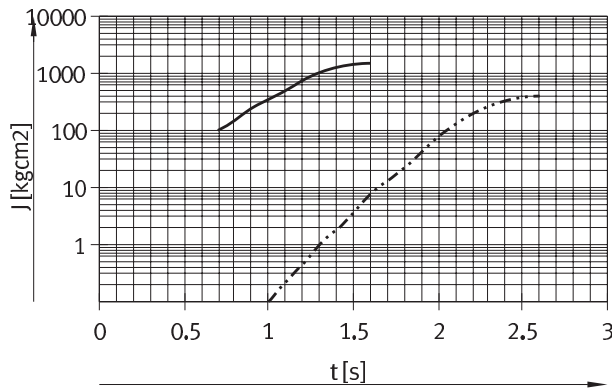

— DRRD-25-...-Y9-PS1 → 100 ... 1500 kgcm²
 - · - · - · DRRD-25-P-PS1 → 0 ... 400 kgcm²

Intermediate position to end position

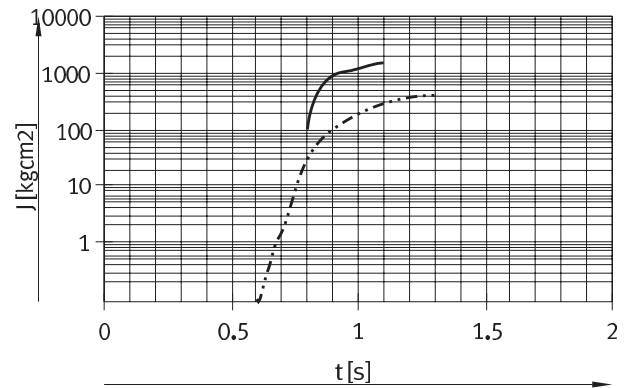

— DRRD-25-...-Y9-PS1 → 100 ... 1500 kgcm²
 - · - · - · DRRD-25-P-PS1 → 0 ... 400 kgcm²

Data sheet

DRRD-...-PS1 – Intermediate position

Max. permissible mass moment of inertia J at the flange shaft as a function of swivel time t

(at room temperature and an operating pressure of 6 bar)

Size 32

End position to intermediate position

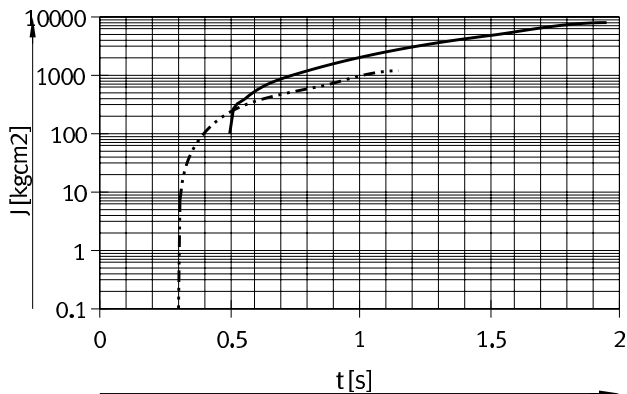

— DRRD-32-...-Y9-PS1 Ranges
 → 100 ... 8000 kgcm²
 - - - DRRD-32-P-PS1 → 0 ... 500 kgcm²

Intermediate position to end position

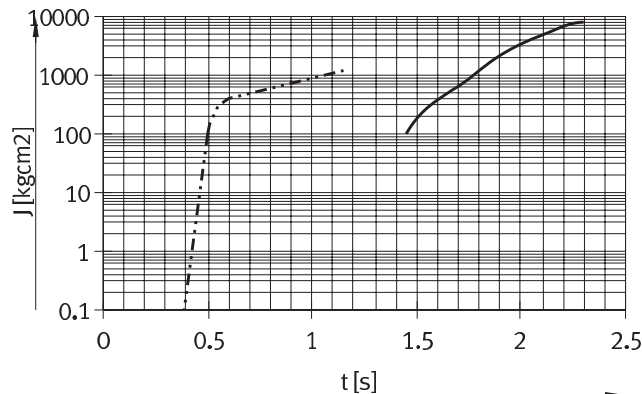

— DRRD-32-...-Y9-PS1 Ranges
 → 100 ... 8000 kgcm²
 - - - DRRD-32-P-PS1 → 0 ... 500 kgcm²

Size 35

End position to intermediate position

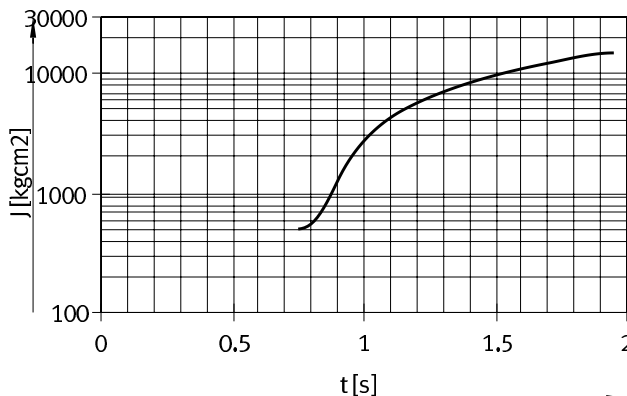

— DRRD-35-...-Y9-PS1 Ranges
 → 500 ... 15000 kgcm²

Intermediate position to end position

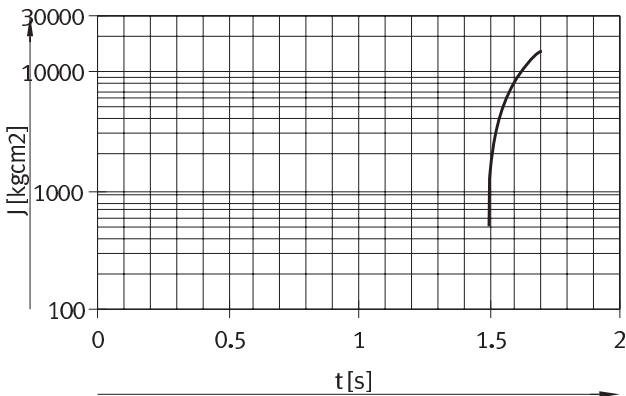

— DRRD-35-...-Y9-PS1 Ranges
 → 500 ... 15000 kgcm²

Data sheet

DRRD-...-PS1 – Intermediate position
 Max. permissible mass moment of inertia J at the flange shaft as a function of swivel time t
 (at room temperature and an operating pressure of 6 bar)

Size 40

End position to intermediate position

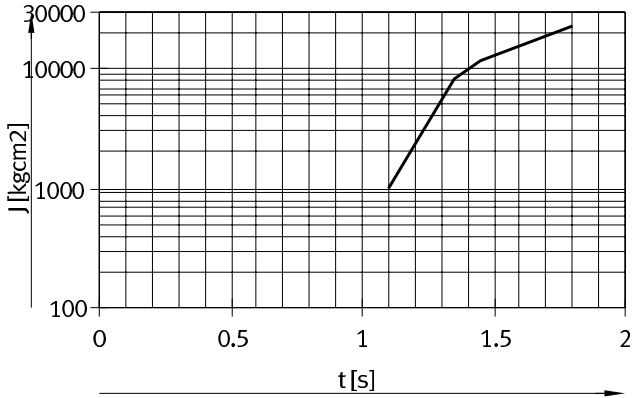

DRRD-40-...-Y9-PS1 Ranges → 1000 ... 23000 kgcm²

Intermediate position to end position

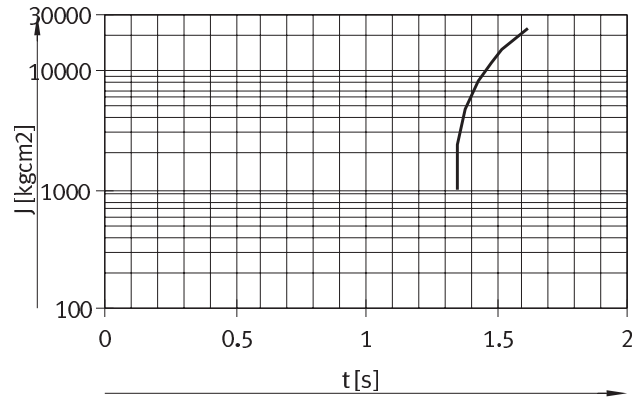

DRRD-40-...-Y9-PS1 Ranges → 1000 ... 23000 kgcm²

Size 50

End position to intermediate position

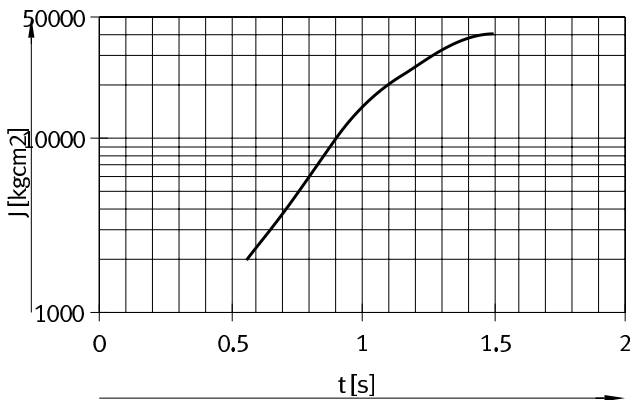

DRRD-50-...-Y9-PS1 Ranges → 2000 ... 40000 kgcm²

Intermediate position to end position

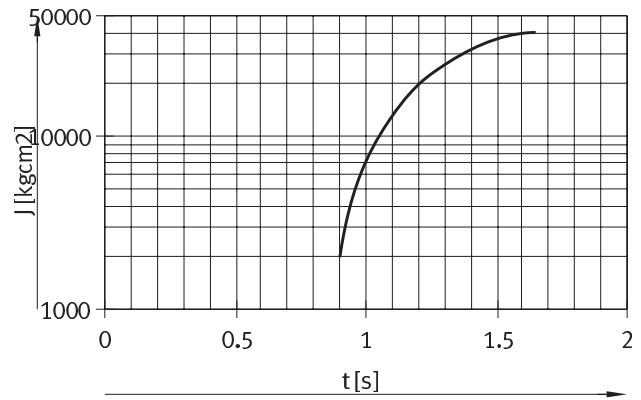

DRRD-50-...-Y9-PS1 Ranges → 2000 ... 40000 kgcm²

Data sheet

Dimensions

Download CAD data → www.festo.com

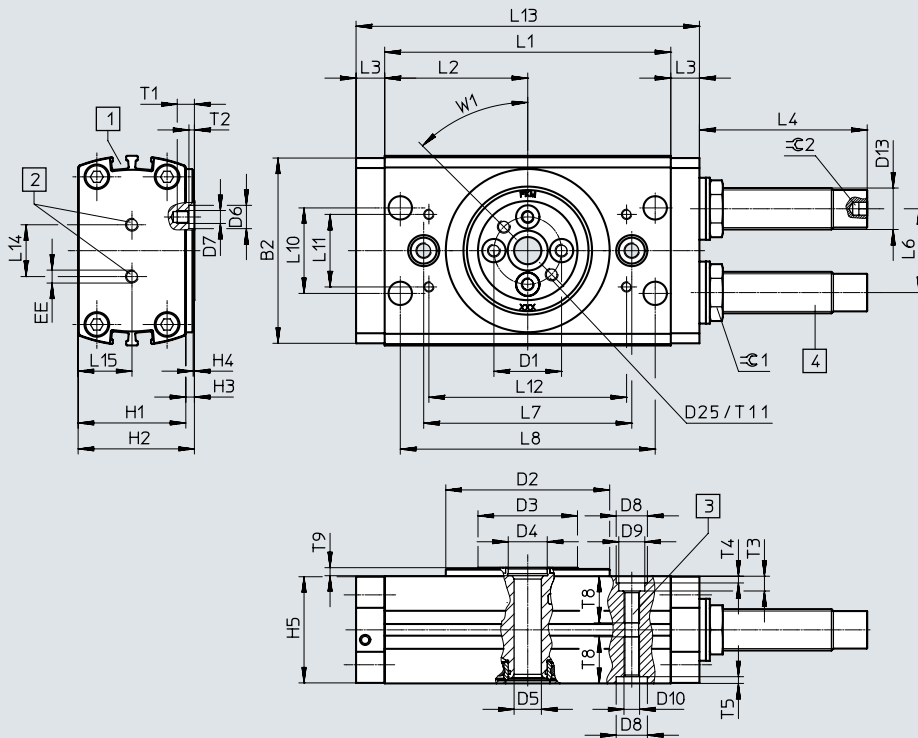

DRRD-32 ... -40

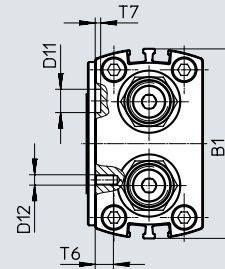

The semi-rotary drive must only be operated with controlled air flow. The flow control should be connected as close as possible to the semi-rotary drive (e.g. one-way flow control valve GRLA-...) → page 64.

Illustrated position of the flange shaft corresponds to the mid-position (swivel angle 90°).

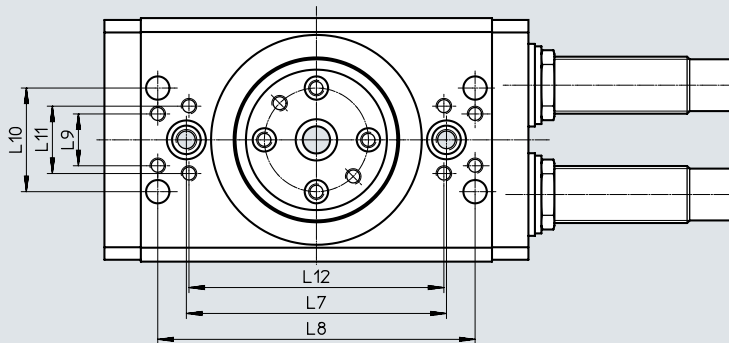

DRRD- ... -P

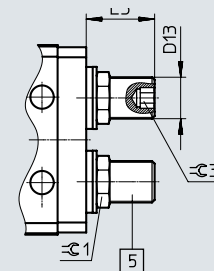

DRRD-50/63

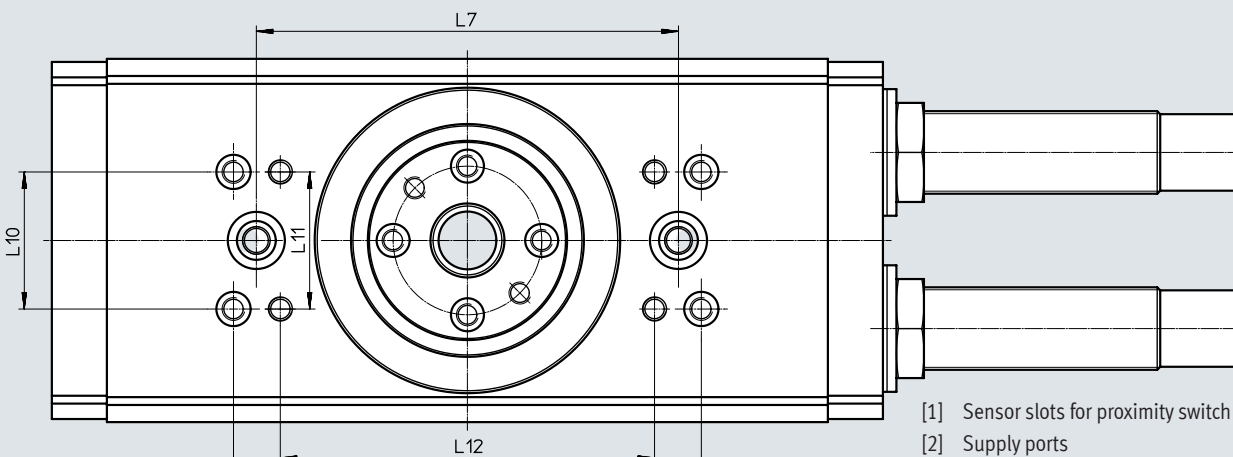

- [1] Sensor slots for proximity switch
- [2] Supply ports
- [3] Mounting thread
- [4] Shock absorber (DRRD-...-Y9/-Y10/-Y14)
- [5] Cushioning elements (DRRD-...-P)

Data sheet

Size	B1 ±0.25	B2	D1 ∅ ±0.025	D2 ∅ +0/-0.05	D3 ∅	D4 ∅ H7	D5 ∅ +0.15/-0.05	D6 ∅ H7	D7	D8 ∅ H7	D9 ∅	D10
16	58	56.2	21	50	32	12	8	7	M4	9	8	M5
20	65	63.4	24	56	34.9	12	8	7	M4	9	8	M5
25	73.2	71.5	26	63	38.25	15	10.5	9	M5	12	10	M6
32	94	92.6	40	81	54.2	15	10.5	9	M6	15	11	M8
35	106	104	45	91	59.9	25	10.5	9	M6	15	11	M8
40	113	111	45	91	59.9	25	21	9	M6	15	14	M10
50	132	129.9	54	110	73	25	21	15	M8	15	14	M10
63	159	157	63	135	82.8	25	21	15	M10	25	17	M12

Size	D11 ∅ H7	D12	D13	D25	H1 ±0.1	H2 +0.2/-0.1	H3 +0.3/-0.2	H4 ±0.1	H5	L1 ±0.1	L2	L3 ±0.1
16	7	M3	M10x1	M4	33	35.6	2.6	0.5	32.6	84	42	10.5
20	9	M4	M12x1	M5	36	39.6	3.6	0.5	35.6	86	43	11
25	9	M4	M16x1	M5	41.4	44.7	3.3	0.5	41	110	55	11
32	9	M6	M22x1.5	M6	50	55.5	5.5	1	49.6	135	67.5	14
35	9	M6	M26x1.5	M6	63	67	4	1	62.2	148	74	15
40	9	M6	M26x1.5	M6	68	72	4	1	67.2	199	99.5	15
50	15	M8	M30x1.5	M8	78	83	5	1	77.2	262	131	20
63	15	M10	M37x1.5	M10	100	107	7	2	99.2	335	167.5	25

Size	L6	L7 ±0.02	L8 ±0.2	L9 ±0.15	L10 ±0.02	L11 ±0.15	L12 ±0.2	L13	L14	L15	T1	T2 +0.1
16	23.2	64	74	–	26	22	61	105	20	16.3	5.6	1.6
20	26	70	74	–	33	14	80	108	20	17.8	6	1.6
25	32.25	80	98	–	33	14	98	132	20	20.5	6.6	2.1
32	42.2	100	122	20	40	26	98	163	30	24.8	8	2.1
35	49.6	120	130	44	26	44	105	178	42	31.1	8	2.1
40	56	120	130	44	26	44	105	229	42	33.6	8	2.1
50	64	160	160	34	34	54	132	302	50	39	10.6	2.6
63	78	170	190	60	60	60	149	385	50	49.6	14	3.1

Size	T3	T4 +0.1	T5 +0.1	T6	T7 +0.1	T8	T9 +0.1	T11	EE	W1	≈ \ominus 1	≈ \ominus 2	≈ \ominus 3
16	4.7	2.1	2.1	6.3	1.6	15	2.6	5.6	M5	45°	13	3	5
20	4.7	2.1	2.1	6.3	2.1	15	2.6	5.6	M5	45°	15	4	6
25	5.7	2.6	2.6	7	2.1	18	3.1	5.5	M5	45°	19	5	8
32	6.5	3.1	3.1	7.8	2.1	23.1	3.1	8	G1/8	45°	27	5	10
35	6.5	3.1	3.1	8.5	2.1	22.6	3.5	8	G1/8	45°	32	6	10
40	8.6	3.1	3.1	9	2.1	32	3.5	8	G1/8	45°	32	6	10
50	8.6	3.1	3.1	10.5	3.1	30	3.5	10	G1/4	45°	36	8	–
63	11	3.5	3.5	14	3.1	40	3.5	14	G3/8	45°	46	8	–

Size	Dimension with 180° swivel angle		Swivel angle adjustment range		
	L4	L5	L4 min./max.	L5 min./max.	1 mm = ...°
16	37	17.6	-20/+1.5	-12/+1.4	8.7
20	41.8	18	-21.1/+1.5	-11/+1.4	9
25	63	24.3	-28.9/+1.9	-15/+1.8	6.6
32	78.3	29.5	-34.7/+2.4	-19/+2.3	5.6
35	97.5	40.9	-34.7/+2.4	-27/+2.3	5.6
40	98.2	41.6	-53/+3.2	-28/+3.1	3.6
50	126	–	-74.5/+4.4	–	2.6
63	120	–	-71.7/+7.1	–	1.9

Data sheet

Dimensions – Variants

Download CAD data → www.festo.com

P... – Energy through-feed, pneumatic

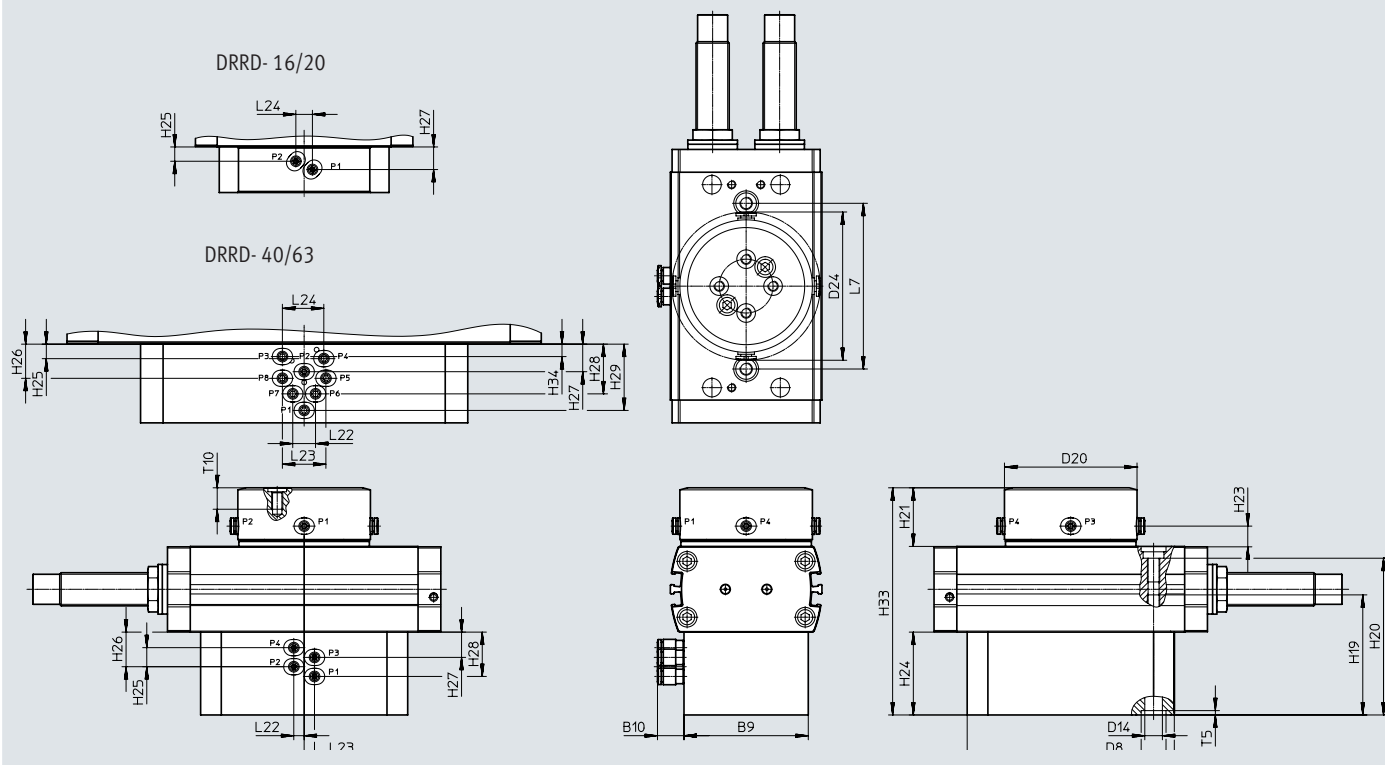

Size	B9	B10	D8 ø H7	D14 ø	D20 ø	D22 ø
16	52	13.4	9	6	54	82
20	58	13.4	9	6	54	82
25	60	12.8	12	6.5	64	100
32	70	12.8	15	8.5	64	120
35	80	12.8	15	8.5	64	138
40	80	13.4	15	11	89	158
50	80	13.4	15	11	89	190
63	80	13.4	25	13	89	210

Size	D24 ø	H19	H20	H21	H23	H24
16	70	43	56.4	16.6	7.6	22
20	70	43	59.3	17.6	8.6	22
25	71.6	57	74.7	28.3	9.8	40
32	71.6	62	82.4	31.5	12	40
35	71.6	61.6	95.5	30	10.5	40
40	96.9	70	97.4	21	10.5	38
50	96.9	68	107.4	24	11.5	38
63	96.9	78	127	29	13.5	38

Data sheet

Size	H25	H26	H27	H28	H29	H33	H34
16	6.9	–	10.9	–	–	71.6	–
20	6.9	–	10.9	–	–	75.6	–
25	7.5	16.7	12.2	21.4	–	109.7	–
32	7.5	16.7	12.2	21.4	–	121.5	–
35	7.5	16.7	12.2	21.4	–	133	–
40	7	16.5	13.3	24	32	127	6
50	7	16.5	13.3	24	32	140	6
63	7	16.5	13.3	24	32	167	6

Size	L7 ±0.02	L22	L23	L24	T5 +0.1	T10
16	64	4	4	8	2.1	8.6
20	70	4	4	8	2.1	8.6
25	80	5	5	–	2.1	9.6
32	100	5	5	–	3.1	11.1
35	120	5	5	–	3.1	11.1
40	120	11	21	20	3.1	10.1
50	160	11	21	20	3.1	14.6
63	170	11	21	20	3.5	17.1

Data sheet

Dimensions – Variants

Download CAD data → www.festo.com

P...E... – Energy through-feed, pneumatic/electrical

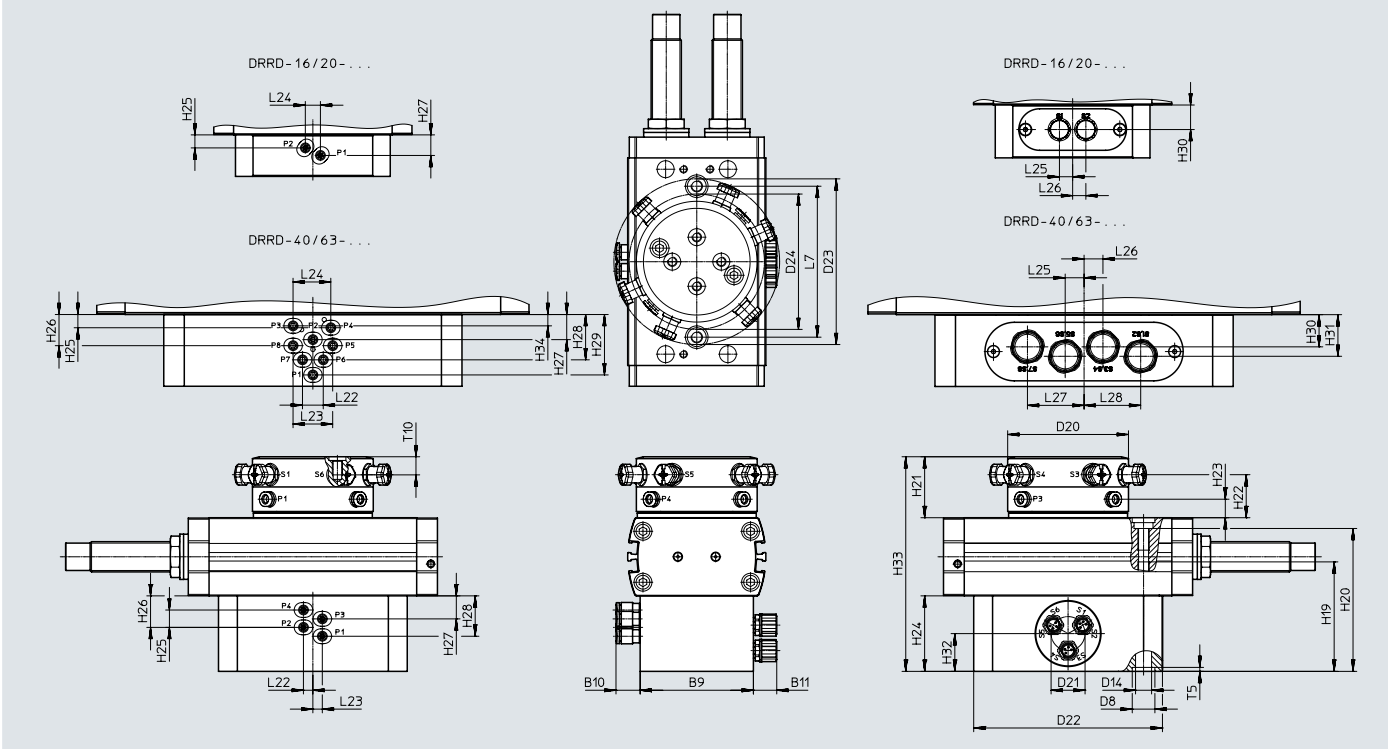

Size	B9	B10	B11	D8 ø H7	D14 ø	D20 ø	D21 ø	D22 ø
16	52	13.4	8.5	9	6	54	16	82
20	58	13.4	8.5	9	6	54	16	82
25	60	12.8	12.4	12	6.5	64	18	100
32	70	12.8	12.4	15	8.5	64	18	120
35	80	12.8	12.4	15	8.5	64	18	138
40	80	13.4	24	15	11	89	–	158
50	80	13.4	24	15	11	89	–	190
63	80	13.4	24	25	13	89	–	210

Size	D23 ø	D24 ø	H21	H22	H23	H24	H25	H26
16	71.1	70	28.6	21.1	7.6	28	6.9	–
20	71.1	70	29.6	22.1	8.6	28	6.9	–
25	89.8	71.6	32.3	22.8	9.8	40	7.5	16.7
32	89.8	71.6	34.5	25	12	40	7.5	16.7
35	89.8	71.6	33	23.5	10.5	40	7.5	16.7
40	138.5	96.9	40	28.5	10.5	38	7	16.5
50	138.5	96.9	44	32.5	11.5	38	7	16.5
63	138.5	96.9	48	36.5	13.5	38	7	16.5

Data sheet

Size	H27	H28	H29	H30	H31	H32	H33	H34	L7 ±0.02
16	10.9	–	–	15.5	–	–	89.6	–	64
20	10.9	–	–	15.5	–	–	93.6	–	70
25	12.2	21.4	–	–	–	20	113.7	–	80
32	12.2	21.4	–	–	–	20	124.5	–	100
35	12.2	21.4	–	–	–	20	136	–	120
40	13.3	24	32	17	22	–	146	6	120
50	13.3	24	32	17	22	–	160	6	160
63	13.3	24	32	17	22	–	186	6	170

Size	L22	L23	L24	L25	L26	L27	L28	T5 +0.1	T10
16	4	4	8	7	7	–	–	2.1	8.6
20	4	4	8	7	7	–	–	2.1	8.6
25	5	5	–	–	–	–	–	2.1	9.6
32	5	5	–	–	–	–	–	3.1	11.1
35	5	5	–	–	–	–	–	3.1	11.1
40	11	21	20	10	10	30	30	3.1	10.1
50	11	21	20	10	10	30	30	3.1	14.6
63	11	21	20	10	10	30	30	3.5	17.1

Data sheet

Dimensions – Variants

Download CAD data → www.festo.com

Y12 – With external shock absorber

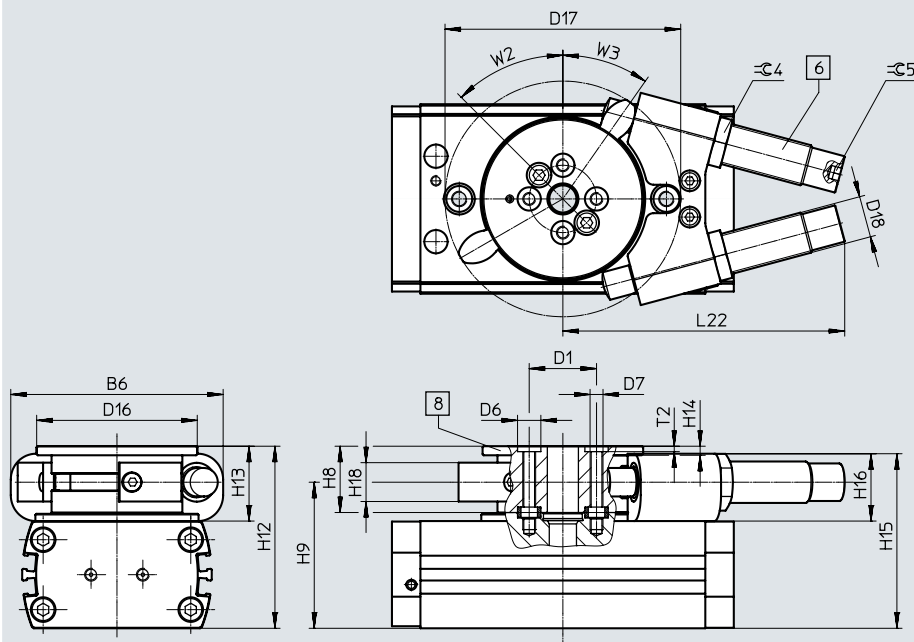

[6] Shock absorber
[8] Flange module

Size	B6 ±0.2	D1 ∅ ±0.025	D6 ∅ H7	D7	D16 ∅	D17	D18	H8 ±0.1	H9	H12
16	58	21	7	M4	49	69.4	M10x1	17	43.1	52.6
20	75	24	7	M4	62	91	M12x1	25.6	51.2	65.2
25	82	26	9	M5	62	91	M16x1	25.6	56.5	70.3
32	120	40	9	M6	79	126.2	M22x1.5	31.5	68.5	87
35	133	45	9	M6	89	146.7	M22x1.5	34	83	101
40	133	45	9	M6	89	146.7	M22x1.5	34	88	106
50	152	54	15	M8	110	165.2	M26x1.5	42	101.5	125
63	186	63	15	M10	130	212.2	M30x1.5	52	129.5	159

Size	H13	H14	H15	H16	H18	L22 max.	T2 +0.1	W2	W3	∠ 4	∠ 5
16	19.6	3.5	51	18	10	65.2	1.6	45°	36°	13	3
20	29.2	3.5	59.5	23.5	15	85.3	1.6	45°	38°	15	4
25	28.9	3.5	67.4	26	15	108.9	2.1	45°	35°	19	5
32	37	4	85	35	22	149.7	2.1	45°	35°	27	5
35	38	5	99	36	21	155.5	2.1	45°	38°	27	5
40	38	5	104	36	21	155.5	2.1	45°	38°	27	5
50	47	6	123	45	30	171.6	2.6	45°	33°	32	6
63	59	6	155.5	55.5	36	228	3.1	45°	36°	36	8

Data sheet

Dimensions – Variants

Download CAD data → www.festo.com

PS1 – Intermediate position

Size 40 and 50

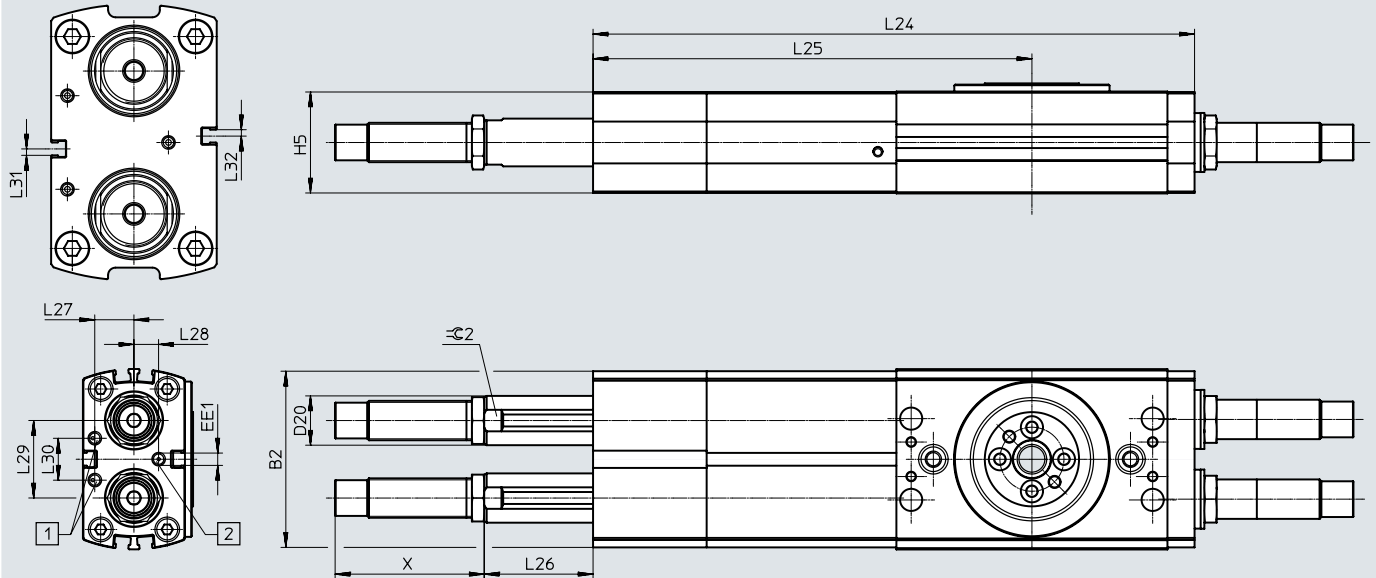

Dimensions for X → page 41



[1] Supply ports to rotate basic drive

[2] Supply port to rotate into intermediate position

Size	B2	H5	L24	L25	L26		L27
					min.	max.	
16	56.2	32.6	193.1	140.6	0.3	21.5	12
20	63.4	35.6	205.1	151.1	4.5	28.4	14
25	71.5	41	244.1	178.1	14.1	44.2	15.9
32	92.6	49.6	320.1	238.6	3.4	43.5	19.5
35	104	62.2	343.1	254.1	14.8	54.5	25
40	111	67.2	392.1	277.6	9	54.1	27
50	129.9	77.2	542.6	391.6	12.3	86	30

Size	L28	L29	L30	L31	L32	D20 ∅	EE1	±0.2
20	9	26.25	16	–	–	16	M5	14
25	10	31.45	17	–	–	20	M5	18
32	14	38.45	16	–	–	28	M5	24
35	18	49.6	18	–	–	32	M5	27
40	14	58	38	2.6	2.6	32	M5	27
50	20	78	44	5	5	36	G1/8	32

Data sheet

Ordering data				
DRRD	Size	Swivel angle [°]	Part no.	Type
P – Elastic cushioning rings/plates at both ends				
	16	180	★ 1577238	DRRD-16-180-FH-PA
	20		★ 1395606	DRRD-20-180-FH-PA
	25		★ 1359980	DRRD-25-180-FH-PA
	32		★ 1578512	DRRD-32-180-FH-PA
	35		★ 1526825	DRRD-35-180-FH-PA
	40		★ 1503269	DRRD-40-180-FH-PA
Y9 – Linear shock absorber, self-adjusting at both ends				
	16	180	★ 1644389	DRRD-16-180-FH-Y9A
	20		★ 1427379	DRRD-20-180-FH-Y9A
	25		★ 1360248	DRRD-25-180-FH-Y9A
	32		★ 1578518	DRRD-32-180-FH-Y9A
	35		★ 1547102	DRRD-35-180-FH-Y9A
	40		★ 1526986	DRRD-40-180-FH-Y9A

Festo core product range



Generally ready for dispatch from the factory within 24 hours

Generally ready for dispatch from the factory within 5 days

Ordering data – Modular product system

Ordering table												
Size	16	20	25	32	35	40	50	63	Conditions	Code	Enter code	
Module no.	574399	574400	574401	574402	574403	574404	574405	574407				
Function	Semi-rotary drive									DRRD	DRRD	
Size	16	20	25	32	35	40	50	63		-...		
Nominal swivel angle	180°									-180	-180	
Output shaft	Flange shaft, hollow									-FH	-FH	
Energy through-feed	None									-		
	Pneumatic, 2 ducts		-							P2		
	Pneumatic, 2 ducts; electric, 2 signals		-							P2E2		
	-		Pneumatic, 4 ducts			-				P4		
	-		Pneumatic, 4 ducts; electric, 6 signals			-				P4E6		
	-		Pneumatic, 8 ducts			-				P8		
	-		Pneumatic, 8 ducts; electric, 8 signals			-				P8E8		
Cushioning	Elastic cushioning rings/plates at both ends									-	-P	
	Linear shock absorber, self-adjusting at both ends										-Y9	
	-		Linear shock absorber, self-adjusting at both ends, hard		-		Linear shock absorber, self-adjusting at both ends, hard				-Y10	
	Linear shock absorber, self-adjusting at both ends, external									[1] [5]	-Y12	
	Linear shock absorber, self-adjusting at both ends, soft									-	-Y14	
Position sensing	Via proximity switch										A	A
EU certification	None											
	II 2GD									[2]	-EX4	
Intermediate position	None									-		
	1 intermediate position									-	[3]	-PS1
End-position locking	None											
	At both ends									[4] [5]	-E1	
Sensor mounting, external	None											
	Mounting rail for proximity switch									[5]	-R	
Version	Standard											
	Splash-proof design										-SG	
Operating instructions	With operating instructions											
	Without operating instructions										-DN	

- [1] **Y12** Not with end-position locking E1 and splash-proof design SG
 [2] **EX4** Not with end-position locking E1, energy through-feed P2E2, P4E6, P8E8 and intermediate position PS1
 [3] **PS1** Not with cushioning Y10, Y14 and with cushioning P only for size 16 ... 32
 [4] **E1** Not with sensor mounting R and splash-proof design SG
 [5] **Y12, E1, R** Not with energy through-feed P2, P2E2, P4, P4E6, P8, P8E8

Accessories

Drive shaft DARF-Q11

For size 12 ... 40

Material:

Tempered steel

RoHS-compliant

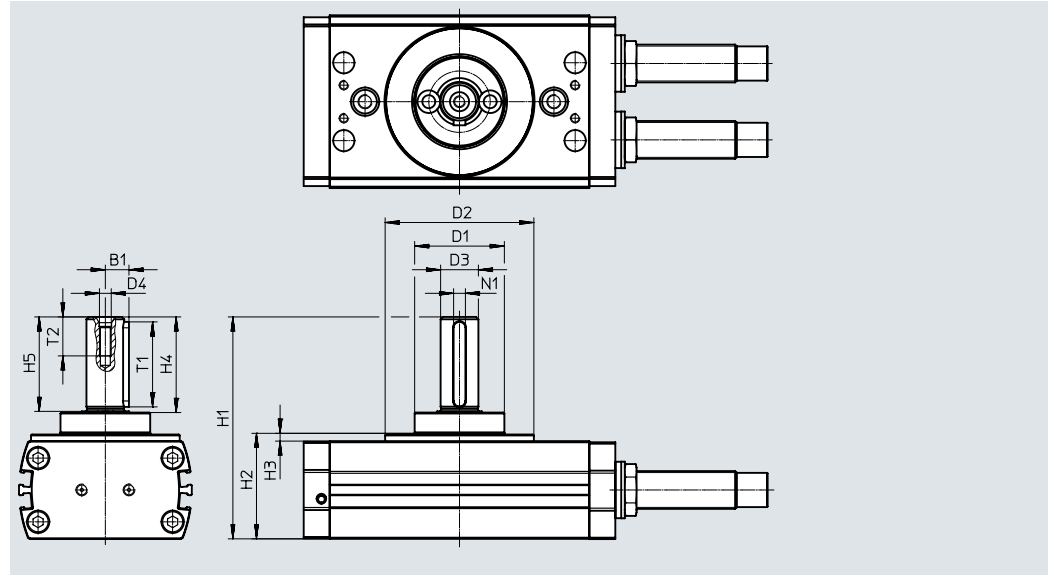
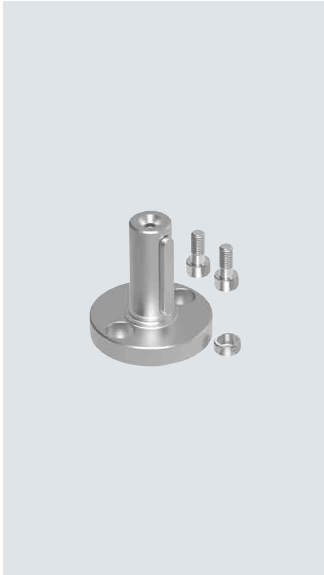

Dimensions and ordering data

For size	B1 +0.1/-0.2	D1 ∅ -0.2	D2 ∅	D3 ∅ g7	D4	H1	H2	H3
12	4.8	30	30	8	M3	56.75±0.3	30.75±0.2	0.75+0.2/-0.6
16	6.2	32	50 _{h7}	10	M3	66.1+0.3/-0.2	35.6+0.2/-0.1	2.6+0.3/-0.2
20	7.5	35	56 _{h7}	12	M4	76.8+0.3/-0.2	39.6+0.2/-0.1	3.6+0.3/-0.2
25	10	38	63 _{h7}	16	M5	94+0.3/-0.2	44.7+0.2/-0.1	3.3+0.3/-0.2
32	12.5	55	81 _{h7}	20	M6	114.8+0.3/-0.2	55.5+0.2/-0.1	5.5+0.3/-0.2
35	13.5	60	91 _{h7}	22	M8	126.2+0.3/-0.2	67+0.2/-0.1	4+0.3/-0.2
40	13.5	60	91 _{h7}	22	M8	131.2+0.3/-0.2	72+0.2/-0.1	4+0.3/-0.2

For size	H4	H5	T1	T2 +2	N1 ²⁾ P9	Weight [g]	Part no.	Type ¹⁾
12	20.5	20±0.1	16 ^{+0.2}	11.6	2	38	4835942	DARF-Q11-12
16	23.5	23±0.1	18.1 ^{+0.3}	11.6	3	60	4835943	DARF-Q11-16
20	30.5	30±0.1	25.1 ^{+0.3}	13.5	4	79	4835941	DARF-Q11-20
25	40.5	40±0.2	36.1 ^{+0.3}	16.5	5	145	4835938	DARF-Q11-25
32	50.5	50±0.2	45.1 ^{+0.3}	21	6	287	4835940	DARF-Q11-32
35	50.5	50±0.2	45.1 ^{+0.3}	32	6	350	4835939	DARF-Q11-35/40
40	50.5	50±0.2	45.1 ^{+0.3}	32	6	350	4835939	DARF-Q11-35/40

1) Suitable for ATEX

2) Feather key to DIN 6885

Accessories

Clamping unit DADL-EL

For size 16 ... 63

(Order code: E1)

Products in stock

Material:

Housing: anodised aluminium

Bearing: plastic

RoHS-compliant

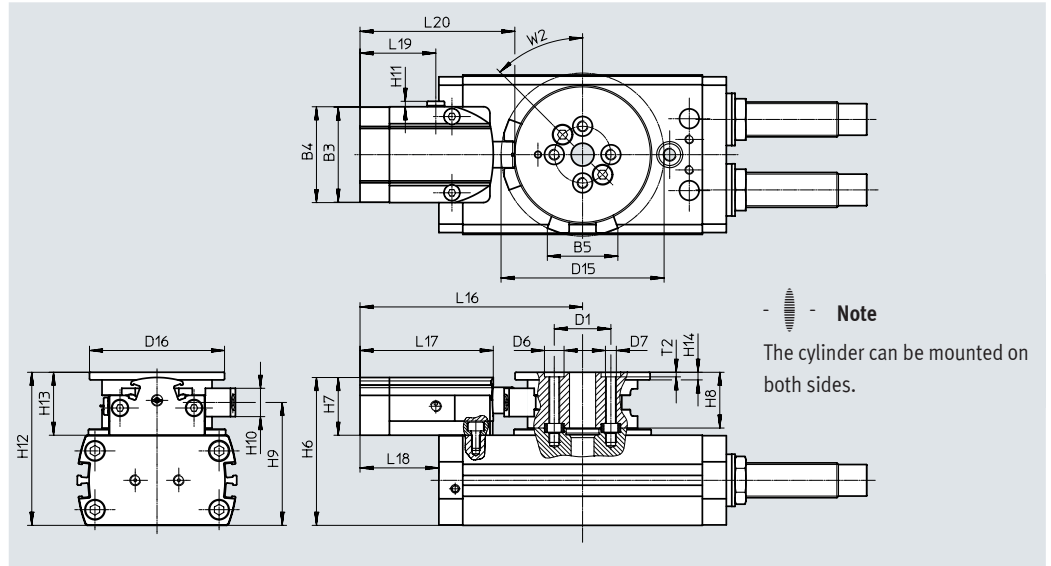

Dimensions and ordering data

For size	B3	B4	B5	D1 ∅	D6 ∅	D7	D15 ∅	D16 ∅	H6	H7	H8	H9
	±0.2	±0.2		±0.025	H7							
16	37.6	38	26.9	21	7	M4	61.9	49	51	18	17	43.1
20	43.6	44	32.4	24	7	M4	74.9	62	62.5	26.5	25.6	51.2
25	43.6	44	32.4	26	9	M5	74.9	62	67.9	26.5	25.6	56.5
32	43.6	44	39.4	40	9	M6	95.4	79	79	26.7	31.5	68.5
35	57.6	58	50.2	45	9	M6	110.9	89	98	35	34	83
40	57.6	58	50.2	45	9	M6	110.9	89	103	35	34	88
50	71.4	72	59.6	54	15	M8	124.3	110	123	45	42	101.5
63	71.4	72	65.8	63	15	M10	148.5	130	149	49	52	129.5

For size	H10	H11	H12	H13	H14	L16	L17	L18	L19	L20	T2	W2
											+0.1	
16	9	2.5	52.6	19.6	3.5	83	50	30.5	34	58.3	1.6	45°
20	13	2.5	65.2	29.2	3.5	102.2	61.2	48.2	34.8	71.1	1.6	45°
25	13	2.5	70.3	28.9	3.5	102.2	61.2	36.2	34.8	71.1	2.1	45°
32	17	2.5	87	37	4	112.2	61.2	30.7	34.8	71.1	2.1	45°
35	14.8	2.5	101	38	5	132.5	70.6	43.5	42.6	85.4	2.1	45°
40	14.8	2.5	106	38	5	132.5	70.6	18	42.6	85.4	2.1	45°
50	19	4.6	125	47	6	151	81	0	46	98	2.6	45°
63	22	4.6	159	59	6	163	81	-29.5	46	99.5	3.1	45°

For size	Pneumatic connection	Operating pressure [bar]	Position sensing	Adjustable swivel angle [°]	Weight [g]	Part no.	Type
16	M5	3 ... 8	Via proximity switch	60 ... 200	166	1692770	DADL-EL-Q11-16
20					382	1579786	DADL-EL-Q11-20
25					370	1568183	DADL-EL-Q11-25
32					600	1631139	DADL-EL-Q11-32
35					900	1544900	DADL-EL-Q11-35/40
40	G1/8	5 ... 8			900	1544900	DADL-EL-Q11-35/40
50					1610	1796637	DADL-EL-Q11-50
63					2380	1941568	DADL-EL-Q11-63

Accessories

Sensing kit DASI-...-KT

For size 16 ... 63

(order code: R)

Products in stock

Material:

Anodised aluminium

RoHS-compliant

For sensing the piston position using inductive proximity switches SIES

→ page 61

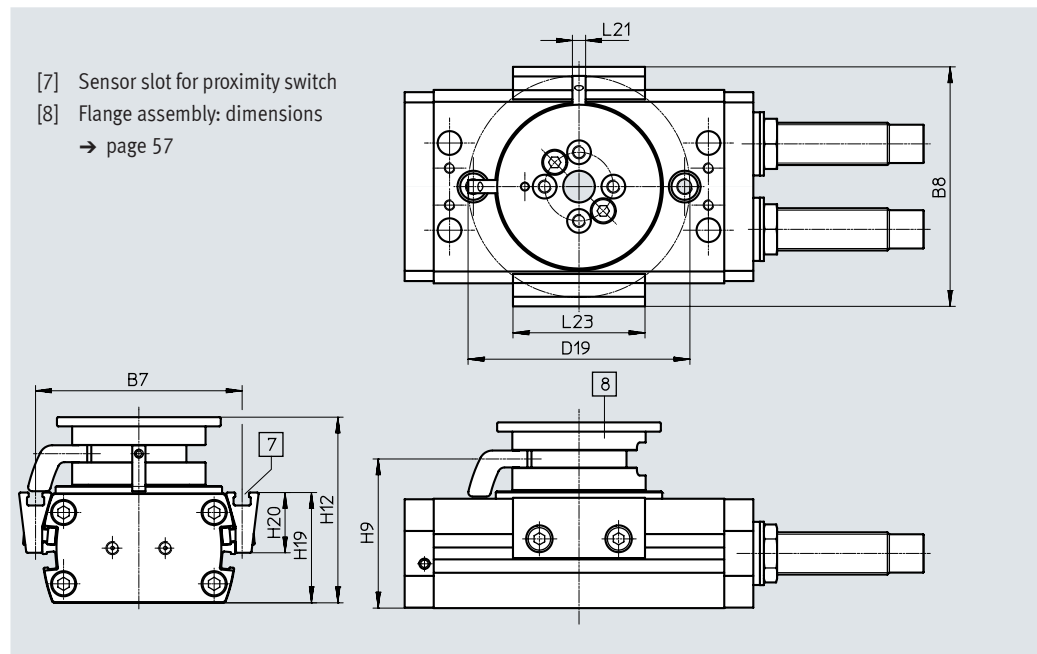
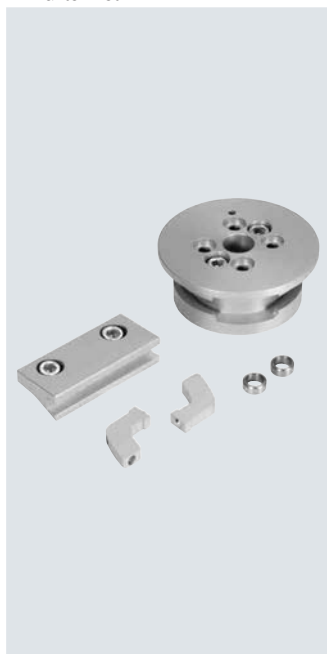





[7] Sensor slot for proximity switch
 [8] Flange assembly: dimensions
 → page 57

Dimensions and ordering data							
For size	B7	B8	D19 ∅	H9	H12	H19	
16	64.4	76.1	70.9	43.1	52.6	33.5	
20	74	85.7	84	51.2	65.2	36.4	
25	78.2	90.7	84	56.5	70.3	41.8	
32	100	113.5	107.5	68.5	87	50.5	
35	116	132.9	125.2	83	101	63.5	
40	118	135.8	125.2	88	106	68.5	
50	136	155.3	146.6	101.5	125	79.1	
63	163	185.3	173.9	129.5	159	101	

For size	H20 ±0.1	L21	L23	Weight [g]	Part no.	Type ¹⁾
16	18.5	5	50	110	1693008	DASI-Q11-16-A-KT
20	20.2	5	50	192	1580899	DASI-Q11-20-A-KT
25	22.8	5	50	192	1568461	DASI-Q11-25-A-KT
32	26.5	7	50	366	1632097	DASI-Q11-32-A-KT
35	33.1	7	50	485	1551144	DASI-Q11-35-A-KT
40	35.5	7	50	485	1550027	DASI-Q11-40-A-KT
50	43	7	50	810	1797135	DASI-Q11-50-A-KT
63	55	7	50	1390	1946877	DASI-Q11-63-A-KT

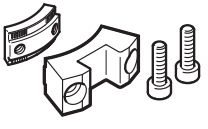
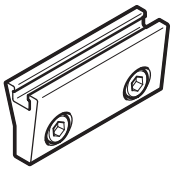
1) Suitable for ATEX

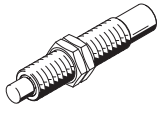
Accessories

Ordering data ²⁾		For size	Description	Weight [g]	Part no.	Type	PE ¹⁾
Clamping component DADL-EC							
	16	For securing an intermediate position in combination with the clamping unit DADL-EL	18	1692496	DADL-EC-Q11-16	1	
	20, 25		36	1435411	DADL-EC-Q11-20/25		
	32		67	1631170	DADL-EC-Q11-32		
	35, 40		98	1535091	DADL-EC-Q11-35/40		
	50		140	1796626	DADL-EC-Q11-50		
	63		220	1941355	DADL-EC-Q11-63		
	Sensor bracket DASI-...-SR³⁾						
	16	Additional sensing option in combination with the sensing kit DASI-...-KT	28	1692983	DASI-Q11-16-A-SR	2	
	20		32	1581420	DASI-Q11-20-A-SR		
	25		32	1568451	DASI-Q11-25-A-SR		
	32		42	1631997	DASI-Q11-32-A-SR		
	35		62	1550870	DASI-Q11-35-A-SR		
	40		62	1548054	DASI-Q11-40-A-SR		
	50		75	1797071	DASI-Q11-50-A-SR		
	63		110	1971563	DASI-Q11-63-A-SR		
Switch lug DASI-...-SL³⁾							
	16	Additional sensing option in combination with the sensing kit DASI-...-KT	2.5	1692969	DASI-Q11-16-A-SL	1	
	20, 25		4	1568436	DASI-Q11-20/25-A-SL		
	32		6	1631824	DASI-Q11-32-A-SL		
	35, 40		8	1548155	DASI-Q11-35/40-A-SL		
	50		10	1797021	DASI-Q11-50-A-SL		
	63		15	1971550	DASI-Q11-63-A-SL		
	Shock absorber DYSC³⁾						
	12	<ul style="list-style-type: none"> Self-adjusting shock absorbers for use as external cushioning (Y12) Included in the scope of delivery for semi-rotary drive DRRD-...-Y12 	9	548011	DYSC-5-5-Y1F	1	
	16		17	548012	DYSC-7-5-Y1F		
	20		36	548013	DYSC-8-8-Y1F		
	25		81	548014	DYSC-12-12-Y1F		
	32, 35, 40		210	553593	DYSC-16-18-Y1F		
	50		370	2479149	DYSC-20-18-Y1F		
	63		575	2480234	DYSC-25-25-Y1F		
Centring sleeve ZBH³⁾							
	8, 10	<ul style="list-style-type: none"> For centring the semi-rotary drive 2 included in the scope of delivery for the semi-rotary drive 	1	186717	ZBH-7	10	
	12, 16, 20		1	150927	ZBH-9		
	25		1	189653	ZBH-12		
	32 ... 50		3	191409	ZBH-15		
	63		5	8023856	ZBH-25		
	8, 10, 12	<ul style="list-style-type: none"> For centring attachments on the flange shaft Centring sleeves are included in the scope of delivery of the attachments 	1	189652	ZBH-5		
	16, 20		1	186717	ZBH-7		
	25 ... 40		1	150927	ZBH-9		
	50		1	189653	ZBH-12		
	63		3	191409	ZBH-15		

- 1) Packaging unit
2) Products in stock
3) Suitable for ATEX

Accessories

Proximity switch for size 8 ... 12

Ordering data – Proximity switch for C-slot, magneto-resistive

Data sheets → Internet: smt

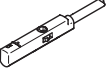
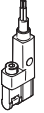
	Type of mounting	Switching output	Electrical connection, outlet direction of connection	Cable length [m]	Part no.	Type
N/O contact						
	Inserted in the slot from above	PNP	Cable, 3-wire, in-line	2.5	★ 551373	SMT-10M-PS-24V-E-2,5-L-OE
			Plug M8x1, 3-pin, in-line	0.3	★ 551375	SMT-10M-PS-24V-E-0,3-L-M8D
			Plug M8x1, 3-pin, crosswise	0.3	551376	SMT-10M-PS-24V-E-0,3-Q-M8D
	Inserted in the slot lengthwise	PNP	Cable, 3-wire, crosswise	2.5	547862	SMT-10G-PS-24V-E-2,5Q-OE
			Plug M8x1, 3-pin, crosswise	0.3	547863	SMT-10G-PS-24V-E-0,3Q-M8D

Ordering data – Proximity switches for C-slot, magnetic reed

Data sheets → Internet: sme

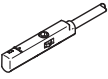
	Type of mounting	Switching output	Electrical connection, outlet direction of connection	Cable length [m]	Part no.	Type
N/O contact						
	Inserted in the slot from above	Contacting	Plug M8x1, 3-pin, in-line	0.3	★ 551367	SME-10M-DS-24V-E-0,3-L-M8D
			Cable, 3-wire, in-line	2.5	★ 551365	SME-10M-DS-24V-E-2,5-L-OE
			Cable, 2-wire, in-line	2.5	★ 551369	SME-10M-ZS-24V-E-2,5-L-OE

Proximity switch for size 16 ... 63

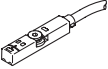
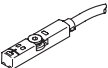

Ordering data – Proximity switches for T-slot, magneto-resistive

Data sheets → Internet: smt

	Type of mounting	Switching output	Electrical connection	Cable length [m]	Part no.	Type
N/O contact						
	Inserted in the slot from above, flush with the cylinder profile, short design	PNP	Cable, 3-wire	2.5	★ 574335	SMT-8M-A-PS-24V-E-2,5-OE
			Plug M8x1, 3-pin	0.3	★ 574334	SMT-8M-A-PS-24V-E-0,3-M8D
			Plug M12x1, 3-pin	0.3	★ 574337	SMT-8M-A-PS-24V-E-0,3-M12
		NPN	Cable, 3-wire	2.5	★ 574338	SMT-8M-A-NS-24V-E-2,5-OE
			Plug M8x1, 3-pin	0.3	★ 574339	SMT-8M-A-NS-24V-E-0,3-M8D
N/C contact						
	Inserted in the slot from above, flush with the cylinder profile, short design	PNP	Cable, 3-wire	7.5	★ 574340	SMT-8M-A-PO-24V-E-7,5-OE

Ordering data – Proximity switches for T-slot, magnetic reed

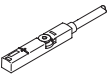
Data sheets → Internet: sme

	Type of mounting	Switching output	Electrical connection	Cable length [m]	Part no.	Type
N/O contact						
	Inserted in the slot from above, flush with the cylinder profile	Contacting	Cable, 3-wire	2.5	★ 543862	SME-8M-DS-24V-K-2,5-OE
				5.0	★ 543863	SME-8M-DS-24V-K-5,0-OE
			Cable, 2-wire	2.5	★ 543872	SME-8M-ZS-24V-K-2,5-OE
			Plug M8x1, 3-pin	0.3	★ 543861	SME-8M-DS-24V-K-0,3-M8D
	Inserted in the slot lengthwise, flush with the cylinder profile	Contacting	Cable, 3-wire	2.5	150855	SME-8-K-LED-24
			Plug M8x1, 3-pin	0.3	150857	SME-8-S-LED-24

Festo core product range



Generally ready for dispatch from the factory within 24 hours



Generally ready for dispatch from the factory within 5 days

Accessories

Proximity switch for size 16 ... 63

Ordering data – Proximity switches for T-slot, inductive

Data sheets → Internet: sies

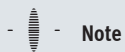

	Type of mounting	Switching output	Electrical connection	Cable length [m]	Part no.	Type
N/O contact						
	Inserted in the slot from above, flush with the cylinder profile	PNP	Cable, 3-wire	7.5	551386	SIES-8M-PS-24V-K-7,5-OE
			Plug M8x1, 3-pin	0.3	551387	SIES-8M-PS-24V-K-0,3-M8D
		NPN	Cable, 3-wire	7.5	551396	SIES-8M-NS-24V-K-7,5-OE
			Plug M8x1, 3-pin	0.3	551397	SIES-8M-NS-24V-K-0,3-M8D
N/C contact						
	Inserted in the slot from above, flush with the cylinder profile	PNP	Cable, 3-wire	7.5	551391	SIES-8M-PO-24V-K-7,5-OE
			Plug M8x1, 3-pin	0.3	551392	SIES-8M-PO-24V-K-0,3-M8D
		NPN	Cable, 3-wire	7.5	551401	SIES-8M-NO-24V-K-7,5-OE
			Plug M8x1, 3-pin	0.3	551402	SIES-8M-NO-24V-K-0,3-M8D

**Note**

The inductive proximity switches SIES can only be used in combination with the sensing kit DASI-...-KT.

Ordering data – Connecting cables

Data sheets → Internet: nebu

	Electrical connection, left	Electrical connection, right	Cable length [m]	Part no.	Type
	Straight socket, M8x1, 3-pin	Cable, open end, 3-wire	2.5	★ 541333	NEBU-M8G3-K-2.5-LE3
			5	★ 541334	NEBU-M8G3-K-5-LE3
	Angled socket, M8x1, 3-pin	Cable, open end, 3-wire	2.5	★ 541338	NEBU-M8W3-K-2.5-LE3
			5	★ 541341	NEBU-M8W3-K-5-LE3

Festo core product range



Generally ready for dispatch from the factory within 24 hours



Generally ready for dispatch from the factory within 5 days

Accessories

Position transmitter for size 16 ... 63

The position transmitter continuously senses the position of the piston.

It has an analogue output with an output signal in proportion to the piston position.

Ordering data – Position transmitter for T-slot

Data sheets → Internet: position transmitter

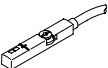
	Type of mounting	Electrical connection	Analogue output [V]	Cable length [m]	Part no.	Type
	Inserted in the slot from above	Plug M8x1, 4-pin, in-line	0 ... 10	0.3	553744	SMAT-8M-U-E-0,3-M8D

Size	16	20	25	32	35	40	50	63
Position measuring range for SMAT-8M [°]	151	120	183	159	185	132	82	64

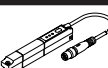
	Position measuring range	Type of mounting	Electrical connection	Analogue output [mA]	Cable length [m]	Part no.	Type
	0 ... 50	Inserted in the slot from above	Plug M8x1, 4-pin, in-line	4 ... 20	0.3	1531265	SDAT-MHS-M50-1L-SA-E-0.3-M8
	0 ... 80					1531266	SDAT-MHS-M80-1L-SA-E-0.3-M8
	0 ... 100					1531267	SDAT-MHS-M100-1L-SA-E-0.3-M8
	0 ... 125					1531268	SDAT-MHS-M125-1L-SA-E-0.3-M8
	0 ... 160					1531269	SDAT-MHS-M160-1L-SA-E-0.3-M8

Ordering data – Connecting cables

Data sheets → Internet: nebu

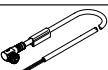
	Electrical connection, left	Electrical connection, right	Cable length [m]	Part no.	Type
	Straight socket, M8x1, 4-pin	Cable, open end, 4-wire	2.5	541342	NEBU-M8G4-K-2.5-LE4
			5	541343	NEBU-M8G4-K-5-LE4
	Angled socket, M8x1, 4-pin	Cable, open end, 4-wire	2.5	541344	NEBU-M8W4-K-2.5-LE4
			5	541345	NEBU-M8W4-K-5-LE4

Accessories

Wiring of the proximity switches in combination with the energy through-feed

Size 16/20

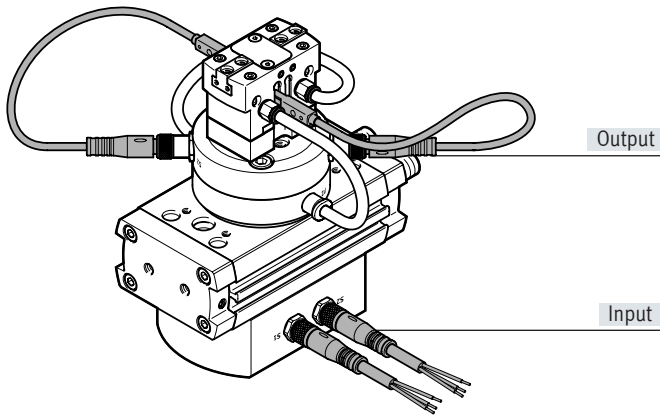

Size 25/32/35

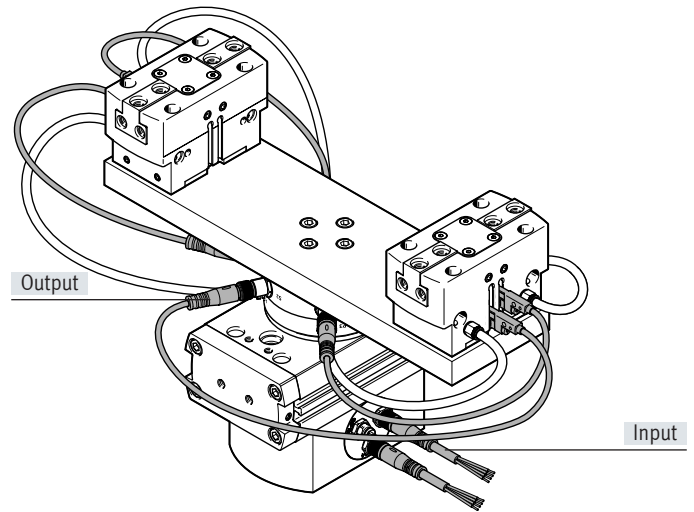

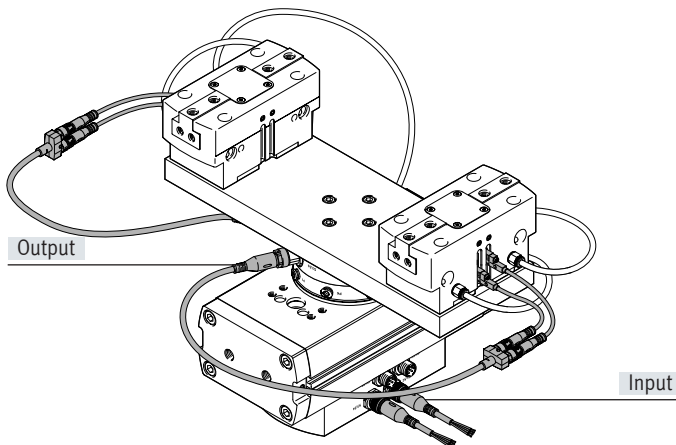

Size 40/50/63



- Note

Proximity switches with plugs must be used for attachments (e.g. grippers) at the output. For sizes 16 ... 35 these can be connected directly to the energy through-feed module.

For sizes 40 ... 63, the proximity switch must be connected to the energy through-feed module through a Y-distributor.

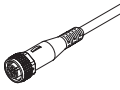
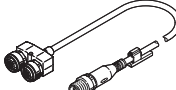
Ordering data	Electrical connection left	Electrical connection right	Cable length [m]	Part no.	Type	Data sheets → Internet: nebu
Input – Connecting cable						
Size 16/20						
	Straight socket, M8x1, 3-pin	Cable, open end, 3-wire	2.5	★ 541333	NEBU-M8G3-K-2.5-LE3	
	Straight socket, M8x1, 3-pin	Cable, open end, 3-wire	5	★ 541334	NEBU-M8G3-K-5-LE3	
Size 25/32/35						
	Straight socket, M8x1, 4-pin	Cable, open end, 4-wire	2.5	541342	NEBU-M8G4-K-2.5-LE4	
	Straight socket, M8x1, 4-pin	Cable, open end, 4-wire	5	541343	NEBU-M8G4-K-5-LE4	
Size 40/50/63						
	Straight socket, M12x1, 5-pin	Cable, open end, 4-wire	2.5	★ 550326	NEBU-M12G5-K-2.5-LE4	
	Straight socket, M12x1, 5-pin	Cable, open end, 4-wire	5	★ 541328	NEBU-M12G5-K-5-LE4	
Output – Y-distributor						
Size 40/50/63						
	Straight plug, M12x1, 4-pin	2x straight sockets, M8x1, 3-pin	0.5 ¹⁾	8032867	NEDY-L2R1-V1-M8G3-U-M12G4-0.5R	
	1) Cable lengths can be selected between 0.3 m and 30 m → Internet: nedyl					

Festo core product range



Generally ready for dispatch from the factory within 24 hours

Generally ready for dispatch from the factory within 5 days

Accessories

Setting the swivel speed

Basic drive and intermediate position module must only be operated with controlled air flow. The flow control should be connected as close as possible to the semi-rotary drive (e.g. one-way flow control valve GRLA-...) → table below

In the event of pressure failure, the payload may hit an end position in an uncontrolled manner. In order to prevent this, piloted check valves HGL or an air reservoir VZS are recommended.

Ordering data – Accessories for basic drive

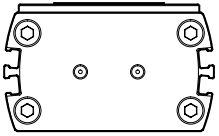

	For size	Description	Weight [g]	Part no.	Type	PE ¹⁾
One-way flow control valve GRLA						
	16 ²⁾ , 20, 25	• To set the swivel speed	14	★ 197576	GRLA-M5-QS-3-RS-D	1
	32, 35, 40		14	★ 197577	GRLA-M5-QS-4-RS-D	
			30	151169	GRLA-1/8-RS-B	
	50		59	151175	GRLA-1/4-RS-B	
			63	97	151178	

1) Packaging unit

Ordering data – Accessories for intermediate position (PS1)

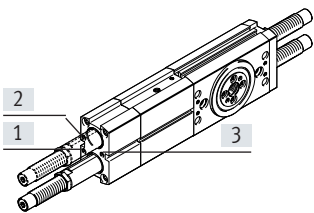

The following movements are adjusted using the supply ports [1] and [2]: end position → intermediate position

Both directions can be adjusted separately from each other.

The following movement is adjusted via supply port [3]:

Intermediate position → end position

Both directions are set simultaneously.

	For size	Description	Weight [g]	Part no.	Type	PE ¹⁾
One-way flow control valve GRLA						
	16 ²⁾ , 20, 25, 32, 35, 40	• To set the swivel speed from the intermediate position	14	★ 197576	GRLA-M5-QS-3-RS-D	1
	50		14	★ 197577	GRLA-M5-QS-4-RS-D	
			30	151169	GRLA-1/8-RS-B	
Check valve HGL						
	20, 25, 32, 35, 40	• For cushioning the payload in the event of a loss of compressed air	21	★ 530029	HGL-M5-B	1
	50		21	★ 530038	HGL-M5-QS-4	
			26	543253	HGL-1/8-1/8-B	
			21	★ 530030	HGL-1/8-B	
Air reservoir VZS						
	16, 20, 25, 32, 35, 40, 50	• For cushioning the payload in the event of a loss of compressed air	8600	192161	VZS-20-B	1

1) Packaging unit

2) Strongly recommended for this size

Festo core product range

- ★ Generally ready for dispatch from the factory within 24 hours
- ★ Generally ready for dispatch from the factory within 5 days

Accessories

Adapter kit DHAA

Material:
Wrought aluminium alloy
Free of copper and PTFE
RoHS-compliant

 **Note**
The kit includes the individual mounting interface as well as the necessary mounting material.

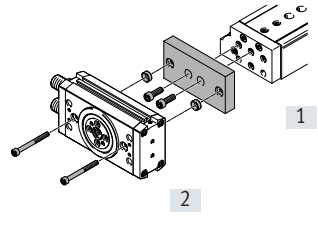
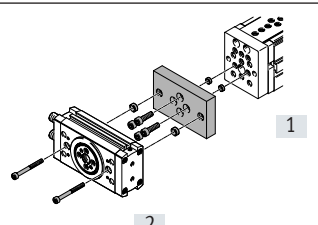
Permissible drive/drive combinations with adapter kit							Download CAD data → www.festo.com
Combination	[1] Drive Size	[2] Drive Size	Adapter kit CRC ¹⁾	Part no.	Type	Quantity required	
	DGSL	DRRD	DHAA				
	4	8	2	2767489	DHAA-D-G6-4-Q11-8	1	
	6	8		2762930	DHAA-D-G6-6-Q11-8		
	8, 10	10		2737394	DHAA-D-G6-8/10-Q11-10		
	12, 16	10		2737247	DHAA-D-G6-12/16-Q11-10		
	8, 10	12		2736429	DHAA-D-G6-8/10-Q11-12		
	12	12		2782718	DHAA-D-G6-12-Q11-12		
	16	12		2734418	DHAA-D-G6-16-Q11-12		
	20	16		1917841	DHAA-D-G6-20-Q11-16		
	20, 25	20		1916912	DHAA-D-G6-20/25-Q11-20		
	25	25		1707360	DHAA-D-G6-25-Q11-25		
	DGSL	DRRD-...-P...E...²⁾	DHAA				
	20	16	2	2332271	DHAA-D-G6-20-Q11-16-E	1	
	20, 25	20		2332452	DHAA-D-G6-20/25-Q11-20-E		
	25	25		2332584	DHAA-D-G6-25-Q11-25-E		
	EGSL	DRRD	DHAA				
	35	8	2	2730033	DHAA-D-E8-35-Q11-8	1	
	35	10		2729506	DHAA-D-E8-35-Q11-10		
	45	10		2728486	DHAA-D-E8-45-Q11-10		
	35	12		2719384	DHAA-D-E8-35-Q11-12		
	45, 55	12		2715152	DHAA-D-E8-45/55-Q11-12		
	55	16		1926914	DHAA-D-E8-55-Q11-16		
	75	16		1928306	DHAA-D-E8-75-Q11-16		
	75	20		1930038	DHAA-D-E8-75-Q11-20		
	EGSL	DRRD-...-P...E...²⁾	DHAA				
	55	16	2	2279410	DHAA-D-E8-55-Q11-16-E	1	
	75	16		2279453	DHAA-D-E8-75-Q11-16-E		
	75	20		2279473	DHAA-D-E8-75-Q11-20-E		

1) Corrosion resistance class CRC 2 to Festo standard FN 940070

Moderate corrosion stress. Indoor applications in which condensation can occur. External visible parts with primarily decorative surface requirements which are in direct contact with a normal industrial environment.

2) With energy through-feed

Accessories

Adapter kit DHAA

Material:
Wrought aluminium alloy
Free of copper and PTFE
RoHS-compliant

 **Note**
The kit includes the individual mounting interface as well as the necessary mounting material.

Permissible drive/drive combinations with adapter kit

Download CAD data → www.festo.com

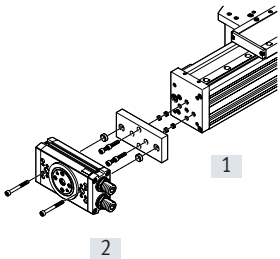
Combination	[1] Drive Size	[2] Drive Size	Adapter kit CRC ¹⁾	Part no.	Type	Quantity required		
ELCC/DRRD	ELCC	DRRD	DHAA					
	60	10	2	2737394	DHAA-D-G6-8/10-Q11-10	1		
	60	12		2736429	DHAA-D-G6-8/10-Q11-12			
	60	16		1675259	DHAA-D-E2-18-Q11-16			
	60, 70	20		1679833	DHAA-D-E2-18/25-Q11-20			
	60, 70	25		1696421	DHAA-D-E2-25-Q11-25			
	70	32		1702297	DHAA-D-E2-25-Q11-32			
	70, 90	32		5154625	DHAA-D-E21-70...110-Q11-32			
	70, 90	35		5154627	DHAA-D-E21-70...110-Q11-35			
	90, 110	40		5154629	DHAA-D-E21-70...110-Q11-40			
	90, 110	50		5154639	DHAA-D-E21-70...110-Q11-50			
	110	63		5154642	DHAA-D-E21-70...110-Q11-63			
	ELCC	DRRD-...-P...E...²⁾		DHAA				
	60	16		2	2328624		DHAA-D-E2-18-Q11-16-E	1
	60, 70	20	2328779		DHAA-D-E2-18/25-Q11-20-E			
	60, 70	25	2328793		DHAA-D-E2-25-Q11-25-E			
	70	32	2328805		DHAA-D-E2-25-Q11-32-E			
	70, 90	32	5154626		DHAA-D-E21-70...110-Q11-32-E			
	70, 90	35	5154628		DHAA-D-E21-70...110-Q11-35-E			
	90, 110	40	5154630		DHAA-D-E21-70...110-Q11-40-E			
90, 110	50	5154640	DHAA-D-E21-70...110-Q11-50-E					
110	63	5154643	DHAA-D-E21-70...110-Q11-63-E					

1) Corrosion resistance class CRC 2 to Festo standard FN 940070

Moderate corrosion stress. Indoor applications in which condensation can occur. External visible parts with primarily decorative surface requirements which are in direct contact with a normal industrial environment.

2) With energy through-feed

Accessories

Adapter kit
DHAA, HAPG

Material:
Wrought aluminium alloy
Free of copper and PTFE
RoHS-compliant

**Note**

The kit includes the individual mounting interface as well as the necessary mounting material.

Permissible drive/drive combinations with adapter kit

Download CAD data → www.festo.com

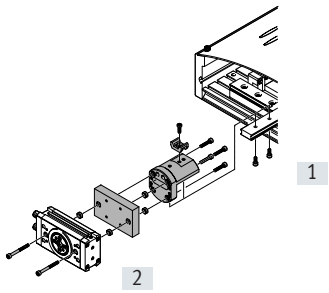
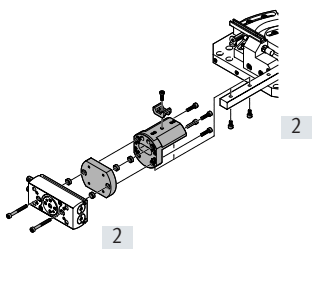
Combination	[1] Drive Size	[2] Drive Size	Adapter kit		Type	Quantity required	
			CRC ¹⁾	Part no.			
	HSP 12	DRRD 8	DHAA		DHAA-D-H4-12-Q11-8 HAPG-70-B	1	
			2	2786084			
				–	540881		
	16	10	DHAA		DHAA-D-H4/H5-12/16-Q11-10 HAPG-71-B		
			2	2785801			
				–	540882		
	16	12	DHAA		DHAA-D-H4/H5-16/25-Q11-12 HAPG-71-B		
			2	2784113			
				–	540882		
	25	12	DHAA		DHAA-D-H4/H5-16/25-Q11-12 HAPG-72-B ³⁾		
2			2784113				
			–	540883			
25	16	DHAA		DHAA-D-H4-25-Q11-16 HAPG-72-B ³⁾			
		2	1919910				
			–	540883			
HSP 25	DRRD-...-P...E... ²⁾ 16	DHAA		DHAA-D-H4-25-Q11-16-E HAPG-72-B ³⁾			
		2	2284940				
			–	540883		1	
	HSW 10	DRRD 8	DHAA		DHAA-D-H5-10-Q11-8 HAPG-69	1	
			2	2789655			
				–	540249		
	12	8	DHAA		DHAA-D-H5-12-Q11-8 HAPG-71-B		
			2	2788114			
				–	540882		
	12	10	DHAA		DHAA-D-H4/H5-12/16-Q11-10 HAPG-71-B		
			2	2785801			
				–	540882		
	16	10	DHAA		DHAA-D-H4/H5-12/16-Q11-10 HAPG-71-B		
2			2785801				
			–	540882			
16	12	DHAA		DHAA-D-H4/H5-16/25-Q11-12 HAPG-71-B			
		2	2784113				
			–	540882			

1) Corrosion resistance class CRC 2 to Festo standard FN 940070

Moderate corrosion stress. Indoor applications in which condensation can occur. External visible parts with primarily decorative surface requirements which are in direct contact with a normal industrial environment.

2) With energy through-feed

3) The centring sleeves for attaching to the adapter kit HAPG-72-B are not required

Festo - Your Partner in Automation



1 Festo Inc.
5300 Explorer Drive
Mississauga, ON L4W 5G4
Canada

Festo Customer Interaction Center
Tel: 1 877 463 3786
Fax: 1 877 393 3786
Email: customer.service.ca@festo.com



2 Festo Pneumatic
Av. Ceylán 3,
Col. Tequesquináhuac
54020 Tlalnepantla,
Estado de México

Multinational Contact Center
01 800 337 8669
ventas.mexico@festo.com



3 Festo Corporation
1377 Motor Parkway
Suite 310
Islandia, NY 11749

Festo Customer Interaction Center
1 800 993 3786
1 800 963 3786
customer.service.us@festo.com



4 Regional Service Center
7777 Columbia Road
Mason, OH 45040

Connect with us



www.festo.com/socialmedia



www.festo.com

Subject to change