

# TC1 SERIES

## Manual Tool Changers | Ordering Information

**Base Model**  
TC1

**Model Size**  
050

**Robot or Tool Plate**  
M-01

### Robot Plate

**M-00** Application Specific - User adds mounting hole pattern

**M-01** ISO-9409-1-50-4-M6 mounting pattern with boss  
(See robot compatibility table on next page)

### Tool Plate

**T-00** Application Specific - User adds mounting hole pattern

**T-01** DirectConnect mounting to DESTACO Robohand products

**T-02** ISO-9409-1-50-4-M6 mounting pattern



Shown mounted to cobot with robot plate and tool plate coupled.



Compatible with multiple brands of cobots.

**TC1-050M-01**  
Robot Plate  
ISO 9409 Mounting  
(see page 3).

Patent Pending

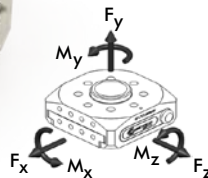

Specifications:		TC1
Max. Payload:	Kg [lb]	10 [22]
Coupled Weight:	Kg [lb]	0.33 [0.73]
Robot Plate Weight:	Kg [lb]	0.20 [0.44]
Tool Plate Weight:	Kg [lb]	0.13 [0.29]
Repeatability:	mm [in]	±0.025 [0.001]
Temperature Range:	C° [F°]	-30° to 66° [-22° to 151°]
Max Moment (My, Mz, Mx)	Nm [in-lb]	100 [885]
Max Force (Fy, Fz)	N [lbf]	1000 [225]
Max Force (Fx)	N [lbf]	100 [22.5]

### Optional Accessories

Description	Order no.
8-Pin M8 Socket Connector Electrical Pass-thru for Robot Plate	<b>TC1-E01M-C01</b>
8-Pin M8 Plug Connector Electrical Pass-thru for Robot Plate	<b>TC1-E02M-C01</b>
8-Pin M8 Plug Connector Electrical Pass-thru for Tool Plate	<b>TC1-E01T-C01</b>
8-Pin M8 Socket Connector Electrical Pass-thru for Tool Plate	<b>TC1-E02T-C01</b>
PNP Magneto-resistive 4mm Sensing Module for Tool Plate	<b>TC1-E01T-P01</b>
NPN Magneto-resistive 4mm Sensing Module for Tool Plate	<b>TC1-E02T-N01</b>
Tool Plate Holder	<b>TC1-050H-01</b>
Seal Replacement Kit	<b>SLKT-480</b>

**TC1-050T-01**  
Tool Plate with DirectConnect  
Robohand Mounting.

# TC1 SERIES

## Manual Tool Changers | Compatibility Charts

### TC1-050M-01 Robot Plate - Robot Compatibility

Robot Manufacturer	Model
GENERIC	Any model with ISO-9409-1-50-4-M6 Pattern
STAUBLI	TX2touch-90, 90L, 90XL
UNIVERSAL ROBOTS	UR3, UR5, UR10, UR16
TECHMAN/OMRON	TM5-700, TM5-900, TM12, TM14
KUKA	LBR iiwa 7 R800, LBR iiwa 14 R820
AUBO	I3, I5, I7, I10
ESI	C-7, C-15
F&P PERSONAL ROBOTICS	P-ROB 2R-24V, 48V
HANWHA PRECISION MACHINERY	HCR-3, 5, 12
JAKA/KUNLIN	ZU 7, 12
MODBOT	COBOT, SCARA
ROZUM	PULSE 75, 90
SIASUN	GCR5, GCR14, GCR20, SCR3, SCR5
HAN'S ROBOTS	ELFIN 3, 5, 10
FRANKA EMIKA	PANDA

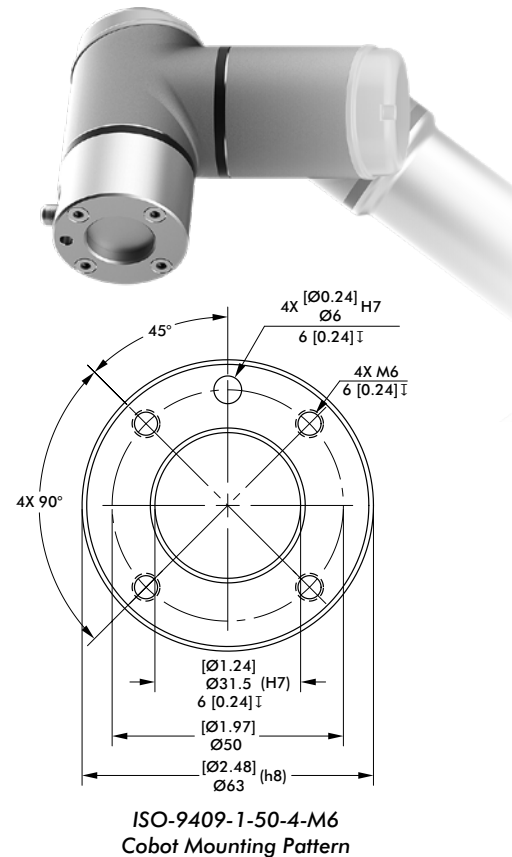

### TC1-050T-01 Tool Plate - Robohand Compatibility

Robohand Products	Compatible Series	Description
DPE	200-25	Electric 2 Jaw Parallel Gripper
DGC	All Sizes	
DPDL	047, 056, 088, 125	
DPDS		
DPG	All Sizes	
DPL	2520, 2535	
DPP	All Sizes	
DPW	250M, 375M, 500M	
G110, G120	All Sizes	Pneumatic 2 Jaw Angular Gripper
DCT	12M, 16M, 20M, 25M	
DRF	All Sizes	Rotary Actuator
DRG		
DLM		Miniature Linear Rail Thruster Slide
DLT		Linear Thruster Slide
DLB	06, 08, 10, 12, 16	Linear Base Slide



Shown with G120 Parallel Gripper and TC1-E01T-P01 Magneto-resistive Sensors.

# TC1 ROBOT PLATE

## Manual Tool Changers | Dimensions

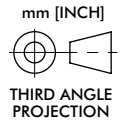

### TC1-050M-00 Blank Robot Plate (general unit dimensions shown apply to all models)



Requires mounting pattern added by user for their specific application.

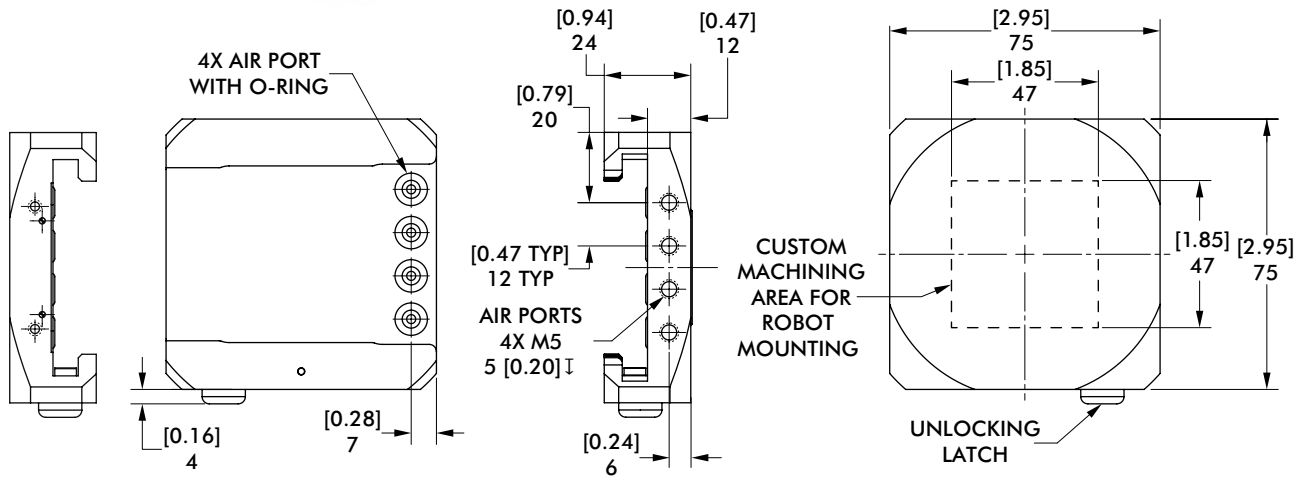
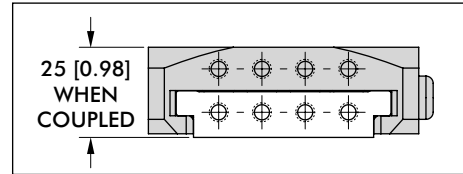

### TC1-050M-01 ISO 9409 Robot Plate (see TC1-050M-00 for general dimensions)



Fasteners, dowel pins, and tools included.

Compatible with multiple brands of cobots. Verify cobot arm mounting pattern.

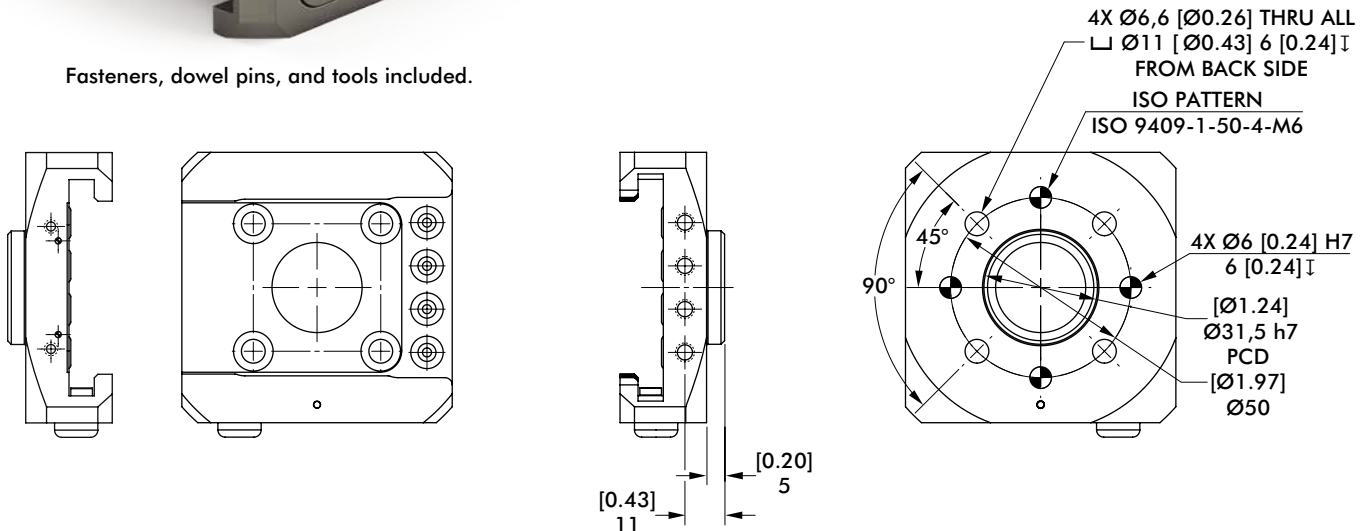
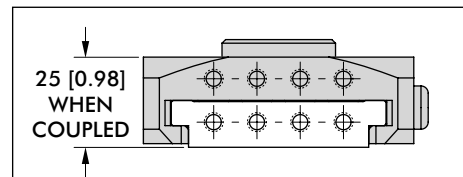

### TC1-050T-00 Blank Tool Plate (general unit dimensions shown apply to all models)

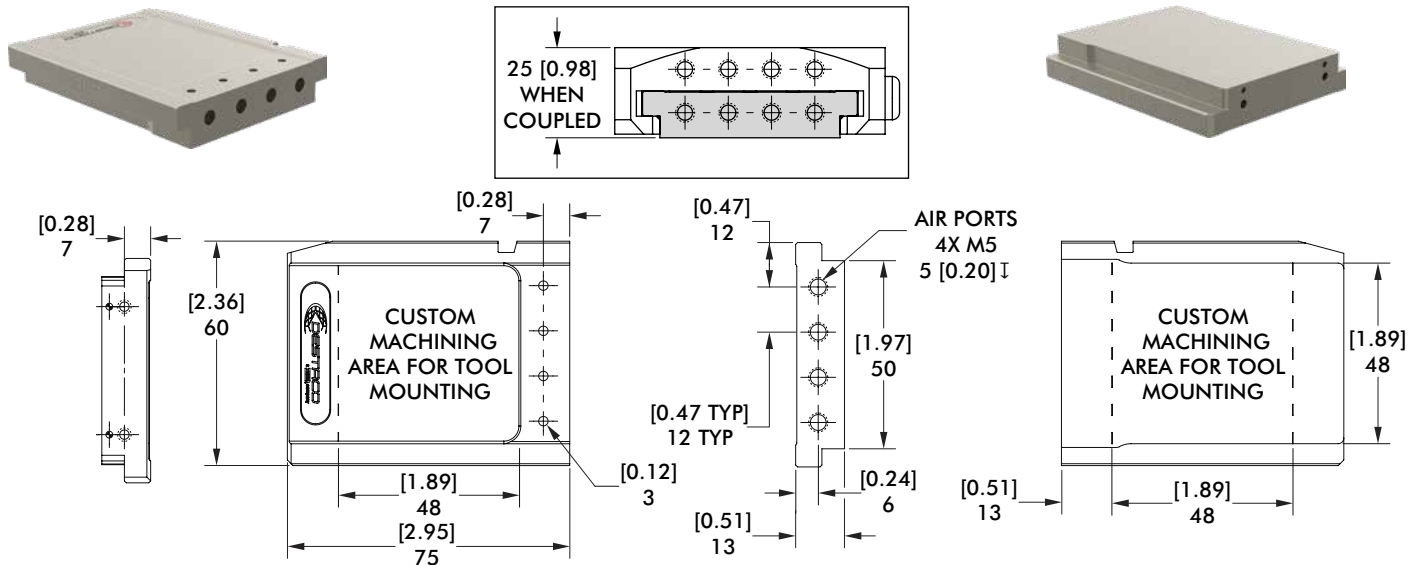

### TC1-050T-01 DirectConnect Robohand Mounting Tool Plate (see TC1-050T-00 for general dimensions)

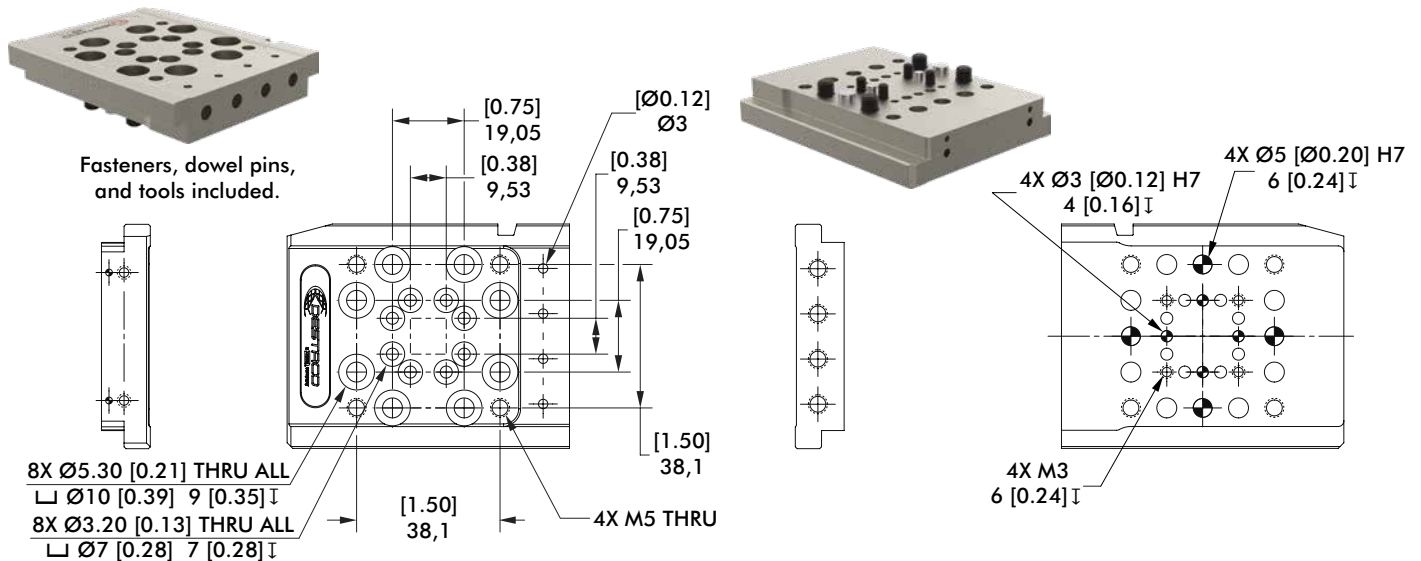

### TC1-050T-02 ISO 9409 Mounting Pattern Tool Plate (see TC1-050T-00 for general dimensions)

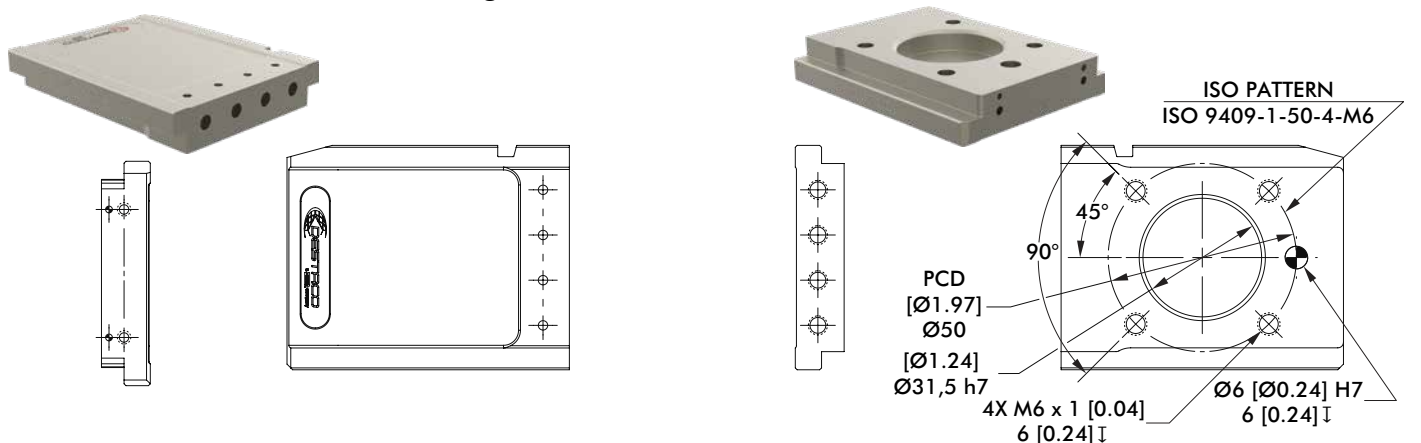

# TC1 ELECTRICAL MODULES

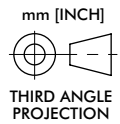

## Manual Tool Changers | Dimensions and Specifications

**TC1-E01M-C01** 8-Pin M8 Socket Electrical Pass-thru Module for Robot Plate (Universal Robot Compatible)

**TC1-E02M-C01** 8-Pin M8 Plug Electrical Pass-thru Module for Robot Plate (TechMan Cobot Compatible)

CABLE LENGTH  
**TC1-E01M-C01** 145 [5.71]  
**TC1-E02M-C01** 175 [6.80]

2X Ø3 [0.12] THRU ALL  
 √Ø6 [0.24] x 90°

PLUG CONNECTOR TC1-E02M-C01    SOCKET CONNECTOR TC1-E01M-C01    INTERFACE PINS

PLUG CONNECTOR TC1-E02M-C01	SOCKET CONNECTOR TC1-E01M-C01	INTERFACE PIN
1	1	1
2	2	2
3	3	3
4	4	4
5	5	8
6	6	5
7	7	6
8	8	7

**TC1-E01M-C01** with 8-Pin M8 Socket shown.  
 Fasteners and tools included.

ELECTRIC SPECIFICATION					
SYMBOL	CHARACTERISTIC	MIN	TYP	MAX	UNIT
V <sub>dd</sub>	CONDUCTOR VOLTAGE	-	-	30	V
I <sub>dd</sub>	CONDUCTOR CURRENT	-	-	1.5	A

**TC1-E01T-C01** 8-Pin M8 Plug Electrical Pass-thru Module for Tool Plate (Universal Robot Compatible)

**TC1-E02T-C01** 8-Pin M8 Socket Electrical Pass-thru Module for Tool Plate (TechMan Cobot Compatible)

2X Ø3 [0.12] THRU ALL  
 √Ø6 [0.24] x 90°

CABLE LENGTH  
 155 [6.10]

PLUG CONNECTOR TC1-E01T-C01    SOCKET CONNECTOR TC1-E02T-C01    INTERFACE PINS

PLUG CONNECTOR TC1-E01T-C01	SOCKET CONNECTOR TC1-E02T-C01	INTERFACE PIN
1	1	1
2	2	2
3	3	3
4	4	4
5	5	8
6	6	5
7	7	6
8	8	7

**TC1-E01T-C01** with 8-Pin M8 Plug shown.  
 Fasteners and tools included.

ELECTRIC SPECIFICATION					
SYMBOL	CHARACTERISTIC	MIN	TYP	MAX	UNIT
V <sub>dd</sub>	CONDUCTOR VOLTAGE	-	-	30	V
I <sub>dd</sub>	CONDUCTOR CURRENT	-	-	1.5	A

# TC1 ELECTRICAL MODULES

## Manual Tool Changers | Dimensions and Specifications

**TC1-E01T-P01** PNP Magneto Resistive 4mm Sensing Module for Tool Plate  
(For use with grippers to detect jaw positioning. Universal Robot Compatible.)

**TC1-E02T-N01** NPN Magneto Resistive 4mm Sensing Module for Tool Plate  
(For use with grippers to detect jaw positioning. TechMan Cobot Compatible.)

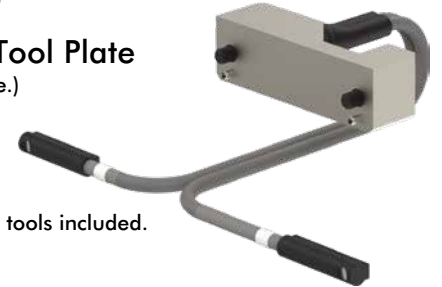

Fasteners and tools included.

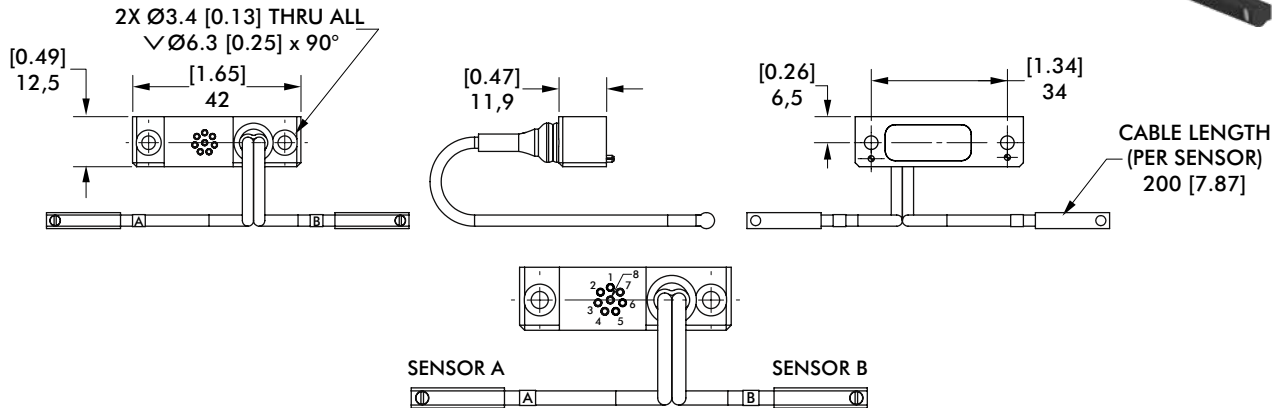

INTERFACE PIN		SIGNAL DESCRIPTION
TC1-E01T-P01	TC1-E02T-N01	
3	3	SIGNAL A
4	2	SIGNAL B
8	1	POWER (4.5~28VDC)
7	7	GND (OV)

ELECTRIC SPECIFICATION					
SYMBOL	CHARACTERISTIC	MIN	TYP	MAX	UNIT
V <sub>dd</sub>	SUPPLY VOLTAGE	4.5	-	28	V DC
I <sub>dd</sub>	OUTPUT CURRENT (PER SENSOR)	-	-	100	mA
I <sub>q</sub>	QUIESCENT (IDLE) CURRENT	-	20	-	mA



Tool Changer shown with **TC1-E01M-C01** and **TC1-E01T-P01** modules installed.



Tool Changer shown with **TC1-E01M-C01** and **TC1-E02T-N01** modules installed.

# TC1 TOOL HOLDER

Manual Tool Changers | Dimensions

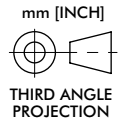

## TC1-050H-01 Tool Holder



Fasteners and tools included.

Material: Acetal Plastic

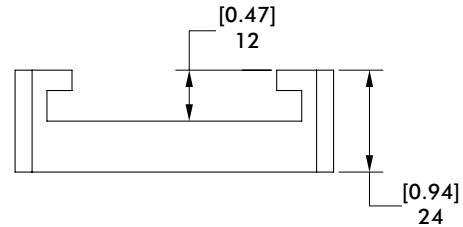
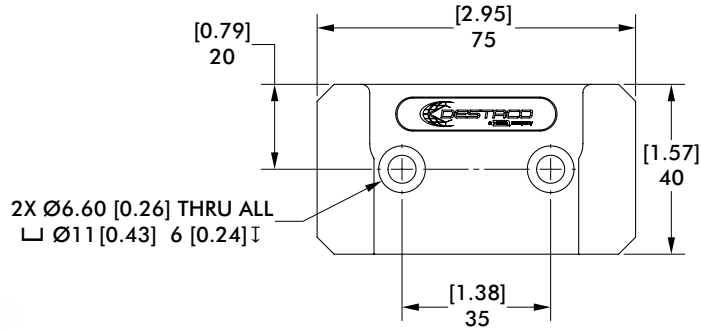

Tool Plate shown with a Robohand DPE-200 Electric Parallel Gripper placed in Tool Holder.



Tool Plate shown placed in Tool Holder.

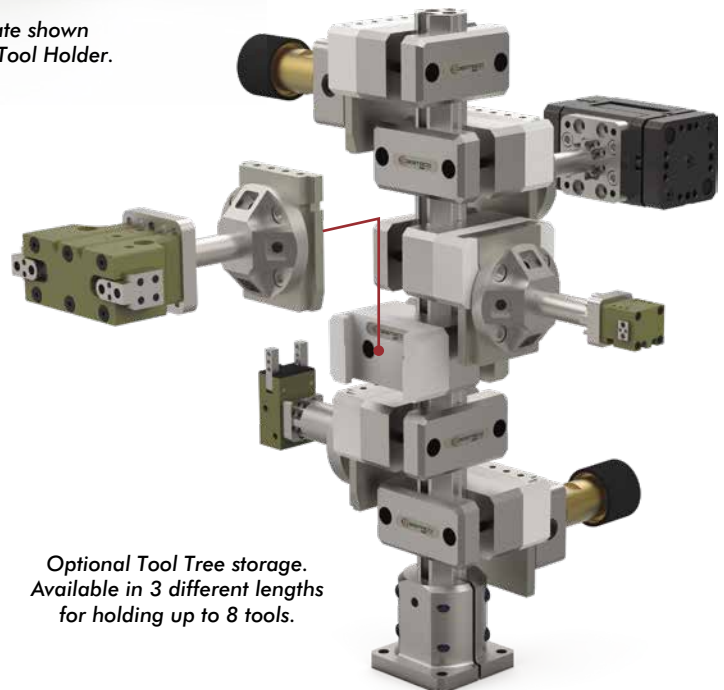

Optional Tool Tree storage. Available in 3 different lengths for holding up to 8 tools.

